

SKB

**TECHNICAL
REPORT**

89-26

**Performance and safety analysis of
WP-Cave concept**

Kristina Skagius¹, Christer Svemar²

¹ Kemakta Konsult AB

² Swedish Nuclear Fuel and Waste Management Co

Augusti 1989

SVENSK KÄRNBRÄNSLEHANTERING AB

SWEDISH NUCLEAR FUEL AND WASTE MANAGEMENT CO

BOX 5864 S-102 48 STOCKHOLM

TEL 08-665 28 00 TELEX 13108-SKB

PERFORMANCE AND SAFETY ANALYSIS OF WP-CAVE CONCEPT

Kristina Skagius¹, Christer Svemar²

1 Kemakta Konsult AB

2 Swedish Nuclear Fuel and Waste Management Co

August 1989

Information on SKB technical reports from 1977-1978 (TR 121), 1979 (TR 79-28), 1980 (TR 80-26), 1981 (TR 81-17), 1982 (TR 82-28), 1983 (TR 83-77), 1984 (TR 85-01), 1985 (TR 85-20), 1986 (TR 86-31), 1987 (TR 87-33) and 1988 (TR 88-32) is available through SKB.

PERFORMANCE AND SAFETY ANALYSIS OF WP-CAVE CONCEPT

Edited by

Kristina Skagius
Kemakta Konsult AB

Christer Svemar
Swedish Nuclear Fuel and Waste Management AB

August 1989

ABSTRACT

This report presents a performance, safety, and cost analysis of the WP-Cave, WPC, concept. In the performance analysis, questions specific to the WPC have been addressed which have been identified to require more detailed studies. Based on the outcome of this analysis, a safety analysis has been made which comprises of the modeling and calculations of radionuclide transport from the repository to the biosphere and the resulting dose exposure to man.

The result of the safety analysis indicates that the present design of a WPC repository may give unacceptably high doses. By improving the properties of the bentonite/sand barrier such that the hydraulic conductivity is reduced, or by changing the short-lived steel canisters to more long-lived canisters, e g, copper canisters, it is judged possible to achieve a sufficiently low level of dose exposure rates to man.

The cost for a WPC repository of the studied design is significantly higher than for a KBS-3 repository considering the Swedish conditions and the Swedish amount of spent fuel. The major costs are connected to the excavation and back-filling of the bentonite/sand barrier. The potential for cost savings is high but it is not judged possible to account for savings in such a way that the WPC concept shows lower cost than the KBS-3 concept.

TABLE OF CONTENTS

	Page
ABSTRACT	i
SUMMARY	ix
1 INTRODUCTION	1
1.1 BACKGROUND	1
1.2 AIM OF PRESENT STUDY	1
1.3 OUTLINE OF REPORT	2
2 WP-CAVE DESIGN AND REPOSITORY PART IN SPENT FUEL HANDLING	5
2.1 GENERAL	5
2.2 DESIGN PHILOSOPHY	5
2.3 WPC DESIGN	6
2.4 SPENT FUEL HANDLING SEQUENCE	8
2.5 FINAL REPOSITORY FOR SPENT FUEL	9
2.5.1 Deposition Method	9
2.5.2 Construction Method	10
2.5.3 Farm of WPCs	11
2.5.4 Depth Below Surface	11
2.5.5 Sealing of Repository	11
2.5.6 Temperature Conditions	13
3 LONG-TERM FUNCTION OF REPOSITORY	15
3.1 GENERAL	15
3.2 FUNCTION OF REPOSITORY	15
3.2.1 Fuel and Canisters	15
3.2.2 Canister Channel	16
3.2.3 Interior Rock Mass	16
3.2.4 Bentonite/sand Barrier	16
3.2.5 Rock mass from Bentonite/sand Barrier to Hydraulic Cage	17
3.2.6 Hydraulic Cage	17
3.2.7 Geosphere	17
3.2.8 Biosphere	17
3.3 SELECTION OF SCENARIO FOR EVALUATION	18

	Page
4	TEMPERATURE DISTRIBUTION 19
4.1	GENERAL 19
4.2	TEMPERATURE DISTRIBUTION WHEN CANISTER CHANNELS ARE FILLED WITH FINELY GROUND ROCK AND WATER 20
4.3	MEASURES TO MEET PEAK TEMPERATURE OF 150°C 24
4.4	CONCLUSIONS 25
5	BUFFER MATERIALS AND MIXTURES 27
5.1	GENERAL 27
5.2	BENTONITE/SAND BARRIER 27
5.2.1	Bottom Cone 28
5.2.2	Cylindrical Part 28
5.2.3	Top Cone 28
5.3	FUNCTION OF BENTONITE/SAND BARRIER 29
5.4	DIFFUSION RESISTANCE 29
5.5	HYDROGEN MIGRATION 30
5.5.1	Through Bentonite/sand barrier 30
5.5.2	Influence of outer rock mass 32
5.6	CONCLUSIONS 33
6	BACK-FILL AND INNER ROCK MASS 35
6.1	GENERAL 35
6.2	BACK-FILLING 35
6.3	INNER ROCK MASS 36
6.4	SORPTION PROPERTIES 37
6.5	CONCLUSIONS 37
7	CANISTER AND LINER CORROSION 39
7.1	GENERAL 39
7.2	CANISTER DESIGN 39
7.3	100-YEAR OPERATIONAL PERIOD 39
7.4	AFTER CLOSURE OF WPC 39
7.4.1	Aerobic Period 40
7.4.2	Anaerobic Period 41
7.5	CANISTER LIFE TIME 41
7.6	HYDROGEN PRODUCTION 42
7.7	CONCLUSIONS 42

	Page	
8	FUEL DISSOLUTION	43
8.1	RELEASE OF RADIONUCLIDES FROM METALLIC COMPONENT	43
8.2	GAP AND GRAIN BOUNDARY RELEASE	43
8.3	UO ₂ MATRIX DISSOLUTION	44
8.4	CONCLUSIONS	45
9	RADIONUCLIDE TRANSPORT IN NEAR FIELD	47
9.1	MIGRATION TO OUTSIDE OF CANISTER	47
9.2	MIGRATION THROUGH SAND BACK-FILL AND INNER ROCK MASS	48
9.3	MIGRATION THROUGH THE BENTONITE/SAND BARRIER	49
9.4	CONCLUSIONS	50
10	THERMALLY INDUCED GROUND WATER FLOW	51
10.1	GENERAL	51
10.2	CALCULATION MODELS	51
10.3	NUMERICAL RESULTS FROM CALCULATIONS	52
10.4	CONCLUSIONS	55
11	GROUND WATER TRANSPORT IN BEDROCK	57
11.1	GENERAL	57
11.2	OBSERVATIONS IN SFR AT FORSMARK	57
11.3	OBSERVATIONS IN KYMMEN TUNNEL	58
11.4	OBSERVATIONS IN STRIPA MINE	58
11.5	CONCEPTUAL MODEL FOR FLOW IN CHANNELS	59
11.6	CONCLUSIONS	60
12	PERFORMANCE OF HYDRAULIC CAGE	61
12.1	GENERAL	61
12.2	CHANNEL MEDIA APPROACH	62
12.2.1	A Fraction of Channels are not Intersected	62
12.2.2	All Channels are Intersected	62
12.3	ATTEMPT TO QUANTIFY DIFFERENCE WITH OR WITHOUT CAGE AT NATURAL GRADIENT	63
12.3.1	Cage Influence on Far Field Stream Lines	63
12.3.2	Calculated Release Rates to Biosphere of some Nuclides	63
12.4	THERMALLY INDUCED FLOW DOMINATES THE RELEASE RATE	64
12.5	CONCLUSIONS	66

	Page	
13	DILUTION OF NUCLIDES IN WELL SCENARIOS	67
13.1	GENERAL	67
13.2	DILUTION IN WELL USED FOR KBS-3 DESIGN	68
13.3	DILUTION FROM WPC IN ONE VERY SMALL WELL	69
13.3.1	Release from Repository	69
13.3.2	Concentration in Water Leaving Repository Near Field	70
13.3.3	Influence of Hydraulic Cage	70
13.4	RELEASE TO A WELL	70
13.5	CONCLUSIONS	71
14	SITE SPECIFIC QUESTIONS	73
14.1	GENERAL	73
14.2	EFFECT ON WPC	73
14.3	PRELIMINARY INFORMATION ON EXISTENCE OF GENTLY DIPPING FRACTURE ZONES	73
14.4	CONCLUSIONS	76
15	RELEASE OF RADIOACTIVE SUBSTANCES	77
15.1	RADIONUCLIDE MIGRATION TO OUTSIDE OF BENTONITE/SAND BARRIER	77
15.1.1	General	77
15.1.2	Calculation Model	77
15.1.3	Release Rates from Bentonite/sand Barrier	81
15.2	RADIONUCLIDE MIGRATION IN GEOSPHERE	85
15.2.1	Calculation Model	85
15.2.2	Release Rates to the Biosphere	86
15.3	HYDRAULIC CAGE	89
15.4	RADIONUCLIDE MIGRATION IN BIOSPHERE AND RESULTING DOSE	90
15.4.1	General Description	90
15.4.2	Calculation Model	91
15.4.3	Resulting Doses to Man	96
15.5	VARIATION CALCULATIONS	101
15.5.1	Effect of Changing Parameters in Near Field	101
15.5.2	Effect of Changing Parameters in Far Field	102
15.6	CONCLUSIONS	102

	Page
16 COST ANALYSIS	105
16.1 GENERAL	105
16.2 WASTE QUANTITIES	105
16.3 TIME SCHEDULE	107
16.4 FACILITIES AND SYSTEMS	108
16.5 COSTS	110
16.6 WPC 1100	112
16.7 VARIATION OF COSTS AFFECTING PARAMETERS	112
16.7.1 Size of WPC	112
16.7.2 Width of Bentonite/sand Barrier	113
16.7.3 Bentonite and Sand Qualities	114
16.7.4 Diameter of Bentonite/sand Barrier	115
16.7.5 Deeper Location of WPC	116
16.8 CONCLUSIONS	116
17 SUMMARY OF CONCLUSIONS	117
17.1 GENERAL	117
17.2 COMMENTS ON RECEIVED SPAN OF DOSE EXPOSURE TO MAN	117
17.3 COMMENTS ON IMPORTANCE OF SOME PARAMETERS	118
17.3.1 Impact by Thermally Induced Flow	118
17.3.2 Impact by Dilution	119
17.3.3 Time of Fuel Dissolution	119
17.3.4 Sorption in Corroded Canister Walls	119
17.3.5 Sorption in Rock Mass Inside Bentonite/sand Barrier	120
17.3.6 Bentonite/sand Barrier Thickness	120
17.3.7 Migration Distance in Geosphere	120
17.4 HYDRAULIC CAGE	120
17.5 ECONOMY	121
17.6 POTENTIAL OF SAFETY	121
17.7 TOPICS REQUIRING FURTHER R&D	121
REFERENCES	123
Appendix 1 RESULT OF SKN STUDY	127
Appendix 2 STUDY ORGANIZATION	129
Appendix 3 ALTERNATIVE WPC DESIGNS	133
Appendix 4 BASIC DATA FOR WPC STUDY	137

SUMMARY

In the R&D program of 1986 SKB extended the scope of its research activities to cover also alternative methods to the KBS-3 method for storing high level radioactive waste. The overall aim was set to form a basis for the selection of the most appropriate method in considering safety, economy, and public acceptance. The method that is the most developed, besides the KBS-3, is the WP-Cave (WPC) method.

The SKB study presented here on the WPC has concentrated on analyzing the long-term performance and safety as well as evaluating the economical potential of the design. No attention has been paid to the question of public acceptance. In all important design matters the recommendations from the basic study financed by the National Board for Spent Nuclear Fuel were adopted. This included the choice of the WPC size, bentonite/sand mixtures in the barrier, and the use of steel canisters for containing the spent fuel. Models for safety analysis and input basic data for calculations have, when no specific information was available, been chosen in accordance with the KBS-3 study. The influence of the most important parameters have been studied by considering different values in the calculations.

The result of the safety analysis is presented as a range of dose exposures to man. The different values within the range are dependent on the scenario and input parameters used in the calculations. The dose estimated is in all the cases analyzed higher or much higher for fission and activation products than for actinides. The peak values of dose range for fission and activation products with a dominating contribution from C-14 is $1 \mu\text{Sv} \cdot \text{a}^{-1}$ to $2\,000 \mu\text{Sv} \cdot \text{a}^{-1}$ for one WPC. Seven WPCs of the analyzed size are required for the Swedish amount of spent fuel. The peak values of actinides, which are reached later in time, vary between $0.5 \mu\text{Sv} \cdot \text{a}^{-1}$ and $700 \mu\text{Sv} \cdot \text{a}^{-1}$. The effect of the hydraulic cage is not considered in these figures. Its function does not become advantageous until the time when the natural groundwater gradient is higher than the thermally induced gradient. This means that its impact is higher on dose rates from actinides than on dose rates from fission and activation products.

The differences between high and low dose range values are mainly due to three factors.

Life-time of canisters. The basis in the release models is that all steel canisters collapse 200 years after repository closure.

Size of thermally induced flow through repository. The driving force is the temperature, which in the study has been limited to 150°C . The resistance in the bentonite/sand barrier depends on the compaction rate that is possible to achieve.

Factor of dilution in the well. The higher dose values are calculated for a dilution factor that is 250 times smaller than the factor estimated in the KBS-3 study. The lower dose values are calculated for the KBS-3 factor. It is logical that a lower dilution factor, within the range set here, is assumed for the WPC than for the KBS-3 due to the shape and depth of location of the WPC.

Further one factor contributes to the difference but only to a minor extent and that is:

Well or well/lake scenario. The well only scenario shows a lower dose rate for fission and activation products than the combined scenario, but not for actinides. The lake adds a dose rate from C-14 in fish.

The total impact from seven WPCs at one location can be expected to increase the dose rate to man above the value for one WPC but not to the value of seven times that from one WPC.

Based on the calculated range of dose rates and measures possible to take, it is judged feasible to design and construct a WPC repository that meets the high demands on long-term safety. Adjustments are, however, foreseen to be required in the analyzed design if comfortably low dose rates are to be achieved. The prime concern is the hydraulic conductivity of the bentonite/sand barrier, which most likely must be improved beyond the values possible for low-graded bentonite/sand mixtures. An alternative and radical adjustment is to change the short-lived steel canisters to a long-lived canister like the copper canister in the KBS-3 study.

The costs for a WPC repository of the analyzed design is significantly higher than the costs for a KBS-3 repository with respect to the Swedish situation. The major parameter is the costs for excavation and backfilling of the bentonite/sand barrier. The potential for cost saving is high but it is not considered possible to reach a level where the WPC is less expensive than the KBS-3.

Major areas requiring further R&D, if the decision is taken to continue the development of the WPC method, are listed in Chapter 17.

1 INTRODUCTION

1.1 BACKGROUND

SKB has within the frame of the 1986 year research and development program initiated studies on alternative designs to the KBS-3 concept for Final Disposal of Spent Fuel. In this report results are presented from a performance and safety analysis of the WP-Cave (WPC) design, carried out during the time period April 1986—December 1988.

The WPC idea originates from 1976, when the first concept was presented by the consulting and constructing company WP System AB, later a company within the Boliden Group /Åkesson och Hök, 1977/. The very early design was analyzed by SKB in 1977 and compared with several other basic ideas as a first stage in the commission given to SKB to develop a method for safe handling and disposal of high-level nuclear waste. The aim of SKB's task was to fulfill the law concerning the special permission to charge nuclear reactors with fuel etc, known as the Stipulations Act. The part of the Stipulations Act concerning final disposal states that the permission may be granted only if the reactor owner has demonstrated how and where an absolutely safe final disposal of spent un-reprocessed nuclear fuel is effected. The outcome of the comparison in 1977 was that the alternative, later known as KBS, was selected.

The WPC idea was further developed by its inventor. In 1982 the National Board for Spent Nuclear Fuel, SKN, took an active part in the work by funding a tentative scientific evaluation of the concept. The results were positive but also indicated some weak points in the design which, however, were possible to overcome by modifications in the design. In 1984 SKN decided to fund a more thorough analysis of specific questions related to the technical feasibility of the alternative. The result of that study further supported the belief that a WPC repository could be constructed in such a way that the man-made barriers would fulfil the quality criteria, which are considered vital for a safe long-term performance. One recommendation for further studies was a detailed safety analysis. Further details on the result of the study are presented in Appendix 1.

1.2 AIM OF PRESENT STUDY

Within the SKB organization the recommendations from the SKN study were adopted and a performance and safety analysis as well as a cost analysis were initiated with the aim of:

- Analyzing long-term performance and safety in such a way that the results would be comparable to those earlier obtained in the analysis of the KBS-3 concept;
- Evaluating the economical potential for WPC in the Swedish back-end system.

The prime technical issue was set to define a WPC repository design and to analyze the performance of the barriers in order to provide a basis for the understanding of how accurate the safety analysis could be performed with presently available data concerning chemistry, hydrogeology, buffer mass properties, etc.

The spent fuel handling process has been analyzed earlier and is not presented in this report.

1.3 OUTLINE OF REPORT

The present study has been carried through with the focus on concept-specific questions, where further exercises were required. The major questions studied have been:

- Thermally induced ground water flow;
- Chemical environment in repository;
- Fuel dissolution;
- Nuclide migration in near-field;
- Nuclide migration in geosphere based on transportation in channels;
- Dispersion in the biosphere.

The project work has been carried out within an organization as presented in Appendix 2. In connection with the listing of different technical studies in the appendix only the most involved researchers and scientists have been mentioned.

The text in the report below is closely adapted to the way of presenting the KBS-3 results. Data, as far as possible, have been taken from the KBS-3 study as well as descriptions and conclusions in questions that are similar in both the WPC and KBS-3 concepts. When new findings have been made these are explicitly pointed out.

In Chapter 2 the design of the WPC repository is presented, its part in the Swedish back-end system, and the processes of construction, fuel disposal, dry supervision, and final sealing. The long-term function of the repository is outlined in general in Chapter 3.

In Chapters 4—14 the results of special studies and considerations for data selection in the safety analysis are presented. In Chapter 4 the temperature distribution calculations are reported. Chapter 5 summarizes the facts on buffer materials proposed to be used in the surrounding barrier. No new laboratory tests have been made and the information is just a compilation of available data. Properties of the central repository and the rock mass inside the bentonite/sand barrier are given in Chapter 6. In Chapter 7 the steel canister design is presented. This chapter also describes the state of the art regarding the knowledge of steel corrosion in anaerobic environments. The spent fuel dissolution process is analyzed in Chapter 8. Chapter 9 discusses the considered models on nuclide transport from the fuel to the flowing water outside the bentonite/sand barrier. In Chapter 10 the results of the estimates of the thermally induced ground water flow are presented. The basis for ground water transportation in channels is outlined in Chapter 11. Some topics concerning the performance of the hydraulic cage structure are analyzed in Chapter 12. Chapter 13 describes the basis for the selection of the size of a well in the most conservative case concerning dispersion in the biosphere. Chapter 14 informs of a tentative analysis concerning the existence of flat fracture zones, which are site specific.

The results of the safety analysis are presented in Chapter 15. The presentation covers the process from fuel dissolution to dispersal in the biosphere. In Chapter 16 the costs are analyzed and a comparison is made between the WPC and KBS-3 for a repository in the Swedish system. Finally, in Chapter 17, a summary of conclusions regarding safety and cost potentials are presented and the impact of important parameters is discussed. The chapter also includes a list of

major R&D topics to be addressed in a program regarding further development of the WPC concept.

2 WP-CAVE DESIGN AND REPOSITORY PART IN SPENT FUEL HANDLING

This chapter describes in general terms the design philosophy of the WPC concept as well as the resulting design, which was chosen for the performance and safety analysis. In brief also the Swedish system for transporting, storing, and disposing of the spent fuel is presented when assuming the WPC as final repository for the spent fuel. In the last part of the chapter methods for disposal of fuel, excavation of repository, and final sealing are presented. The temperature conditions during the different periods are described.

2.1 GENERAL

The difference of interest to discuss in this study compared with the KBS-3 concept is the underground part of the repository for final disposal of spent fuel, which for the WPC concept is based on a totally different layout.

The same fundamental principle for the repository, however, remains; that the long-term safety of the repository shall not be dependent on supervision once the repository has been closed and access shafts and drifts sealed off.

The WPC concept is, as well as the KBS-3 concept, designed as a multibarrier system meaning that the performance of the barriers in the long run are not completely dependent on each other. A failure in one barrier does not result in a failure in any of the other barriers.

The spent fuel considered in this study is the same as described in the KBS-3 report /KBS-3, Chapter 3, 1983/.

2.2 DESIGN PHILOSOPHY

The main consideration with the WPC idea is to isolate the fuel from the surrounding bedrock by one or several barriers, which are to be man-made. As a consequence the fuel is placed very compact inside those barriers. By engineered design it was initially figured that the barriers could be adapted to the rock conditions at most sites in Sweden. It was also judged possible to place the repository rather shallow, so that the top part lies about 200 m below surface.

The clay shell is expected to provide a low-permeable shield that will extend the time for water-filling of the inner parts to such an extent that the life-time of the canisters would be of less importance. Therefore a short-lived steel canister is proposed instead of a long-lived copper canister.

During the operational phase the repository is air-cooled. The system permits the repository to accept also very young fuel, and thus to adopt the function of an interim storage initially. In Sweden, however, a special plant for interim storing, CLAB, is already in operation.

The placing of the canisters is made in such a way that they are retrievable as long as the repository is open, which is intended to be for at least one generation. Hereby the decision of choosing another method for final disposal is possible to be made during a foreseeable, long time into the future.

2.3 WPC DESIGN

The design of the WPC is schematically shown in Figure 2-1. The spent fuel is placed in the centre and surrounded by a buffer of intact rock, which in turn is totally surrounded by a slot which is excavated and re-filled with a low permeable material (bentonite/sand mixture). The structure varies in size but in the course of the present study an outer diameter of the bentonite/sand barrier on the order of 100 m and a height on the order of 300 m has been analyzed. This design is called WPC 1100, with the value 1100 indicating the approximate capacity in tonnes of U.

Outside the bentonite/sand barrier, tunnels and vertical drillholes are arranged in a pattern that forms a totally surrounding cage, a so called hydraulic cage. The cage is assumed to be located 50 m away from the bentonite/sand barrier.

The central part of the repository, see Figure 2-2, consists of a vertical shaft in the centre from which 12 canister channels are directed radially outwards with an inclination of 30 degrees downwards from the horizontal. Those channels have a somewhat larger diameter than the canisters, so that ample distances are available between the canisters and the channel walls for cooling air to pass. Both ends of the storage section in the channel are connected to a vertical shaft for air circulation. The layout is made for the warm air to raise in the inner shafts. After heat exchange the air is recirculated downwards in the outer shafts.

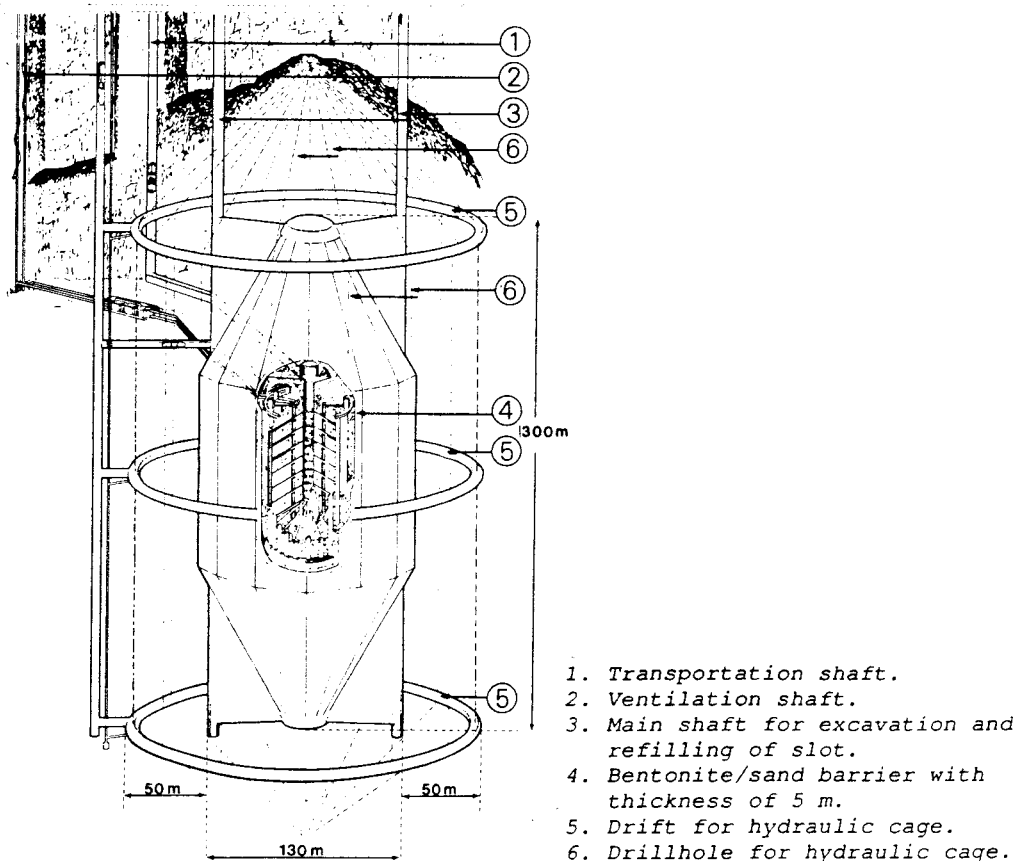
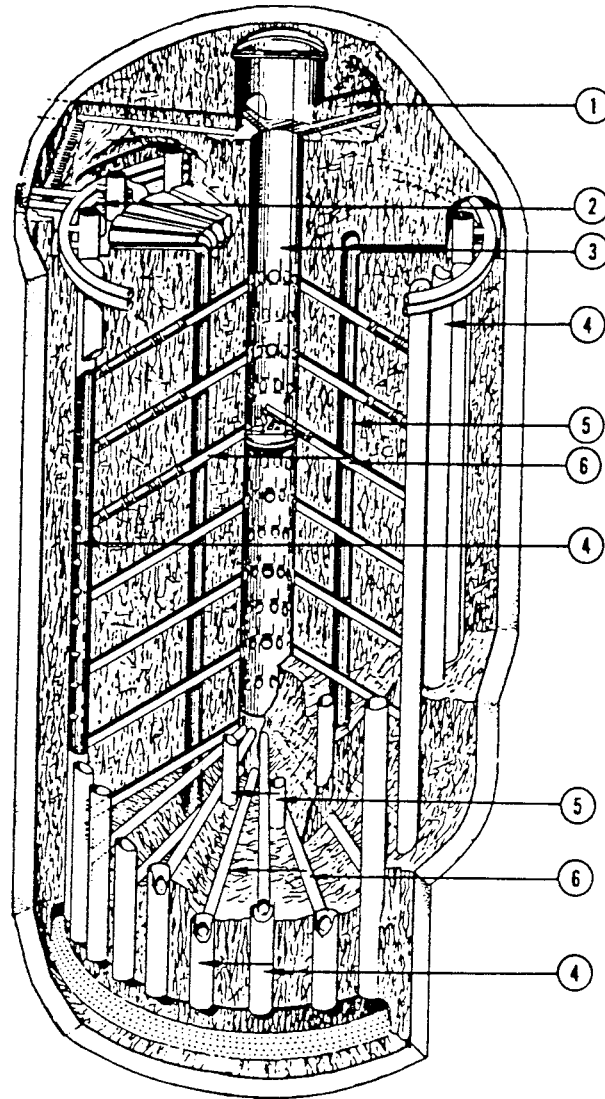

Figure 2-1. Overview of analyzed WPC design.



- | | |
|--------------------------|----------------------------|
| 1. Bulk storage room | 4. Outer ventilation shaft |
| 2. Heat exchange | 5. Inner ventilation shaft |
| 3. Central storage shaft | 6. Canister channel |

Figure 2-2. Central part of repository.

In WPC 1100 two canisters are stored in each canister channel. The measures further assume a number of 12 canister channels per level and 16 levels. This provides a place for a total of 384 canisters, which corresponds to 1/7 of the Swedish program of spent fuel. The height of the inner and outer ventilation shafts are about 110 m.

All shafts and channels in the inner repository are supposed to be covered with steel liners in order to provide a clean atmosphere in air circulation paths. Concrete has been excluded as a preliminary analysis indicated that no specific advantage is gained by having this material present.

The rock buffer between the inner repository and the bentonite/sand barrier has the function of protecting the bentonite material from too high temperatures. With a design peak temperature of 80°C in the bentonite, the thickness of the rock buffer is calculated to be about 25 m /SKN Report 16, Chapter 13,

1985/. The bentonite/sand barrier is basically assumed to have a thickness of 5 m, which is a figure originally chosen to be wide enough for high capacity excavation equipments.

The back-fill of the barrier is planned for different mixtures of bentonite and sand. One design factor is the cost since bentonite is much more expensive than sand. The other is the properties of the mixture that will allow for the lowest bentonite grade of the mixtures. Furthermore, in the bottom part of the barrier a high-friction material is required because it will carry the total load of the interior rock mass. Such a property is favoured by a high sand content. In earlier studies /SKN Report 16, Chapter 6, 1985/ it has been concluded that a 10% bentonite and 90% sand mixture could be suitable. Along the cylindrical part a somewhat lower hydraulic conductivity is considered to be an advantage. From a cost analysis point of view a 20% bentonite mixture is assumed. In the top part a very low hydraulic conductivity is desired, but contradictory to this a high gas conductivity might be required. In the cost analysis a 50% bentonite mixture has been assumed, but the safety analysis also considers a mixture of only 10% bentonite.

2.4 SPENT FUEL HANDLING SEQUENCE

The spent fuel handling system with the WPC as the final repository is displayed in Figure 2-3.

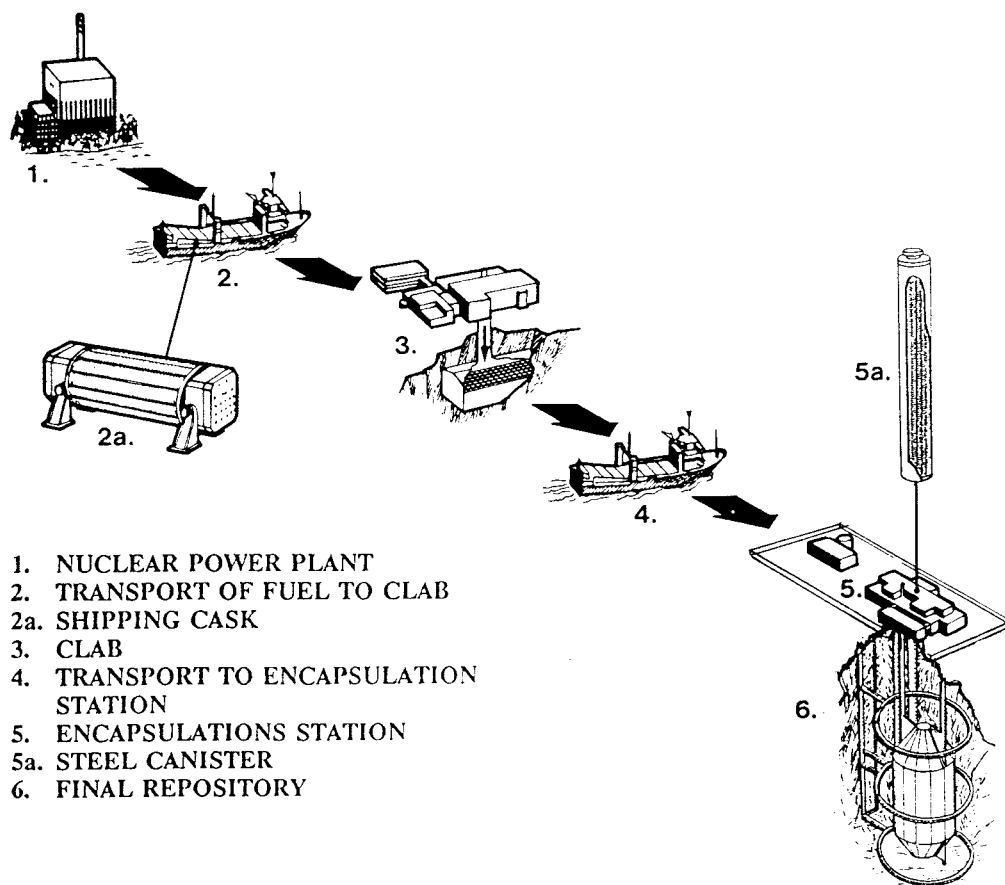

Figure 2-3. Handling sequence for spent fuel with WPC repository.

1. The spent fuel is stored in water pools at the nuclear power stations for a period of at least six months.
2. In campaigns the fuel is transported by sea to CLAB, the interim storage, situated close to the Oskarshamn's nuclear power station on the Swedish east coast.

The CLAB facility has been in operation since 1985.

3. At CLAB the fuel is stored in underground water pools. The time of storage in CLAB is determined by the plan for final disposal of the fuel. At present plan, disposal in Sweden is to start in year 2020, CLAB would be emptied before year 2035 if the WPC concept is introduced.

The fuel is placed in special canisters containing 16 BWR-assemblies or 5 PWR-assemblies which are positioned in the underground water pools.

4. At final disposal the spent fuel is transported from CLAB to the site of the final repository. This place has from a cost analysis point of view been placed in the inland of Sweden, implying transports by ship, railway, and truck.

The transport casks, which hold the same number of assemblies as the CLAB canisters (16 pieces), are loaded in CLAB and unloaded in the encapsulation station at the site of the final repository.

5. The encapsulation station is assumed to be located on the surface right above the repository. The capacity of the canisters assumed in this study is the same as that of the CLAB canisters and the transport casks. This will give a load of about 3 tonnes of U per canister which is twice as much as the designed criterion for the copper canister described in conjunction with the KBS-3 concept.
6. At the end of the encapsulation line the canisters are lowered down to repository level and positioned in the WPC.
7. The high thermal load in each WPC (also in WPC 1100) requires a certain period of time (100 years assumed) for air-cooling and heat exchange before the repository can be closed and sealed off.

2.5 FINAL REPOSITORY FOR SPENT FUEL

2.5.1 Deposition Method

The canisters with the fuel are transported from the surface down to the underground in the main shaft, which is located outside the hydraulic cage. When several caves are constructed at the same site, the main shaft is used by all caves. At repository depth the canisters are transferred from the shaft into the repository via the transportation drift. The positioning of the canisters in the canister channels is made from a special platform operating in the central shaft inside the bentonite/sand barrier.

The air circulation in the central repository for cooling of the canisters is started up by the help of fans. The fans will help to assure that the intended direction of air circulation will develop. When the air circulation has started it is considered possible to maintain the canister cooling by self-circulation of the air /SKN Report 16, Chapter 12, 1985/.

2.5.2 Construction Method

After the site is selected a more detailed investigation from the surface is to take place, which will result in a preliminary location of the WPC in the horizontal plane as well as in the vertical plane. Based on this preliminary location the shaft for the hydraulic cage is sunk (or in case of a farm of WPCs, the central shaft and horizontal tunnels up to the location of the cage). The annular tunnels in the cage are then driven. All or only a proportion of the drains in the cage are drilled.

When the cage is ready, water pumping is started and the exact positioning of the repository is made, the excavation and re-filling of the bentonite/sand slot starts. All communication with the slot is made via two transportation and communication shafts and no links are required between the slot and the hydraulic cage. When the two shafts are ready and furnished with hoisting equipment, the excavation and re-filling start in the bottom. The water pumping in the hydraulic cage drains the rock mass inside and provides a dry environment for the slot construction. The excavation and re-filling of the slot are made in accordance with the conventional mining technique "cut-and-fill" /White, 1984/. The principle is to excavate a certain height of the slot, about 5 m, and re-fill the excavated volume. The top of the back-fill is used as the floor for excavation and re-filling of the next section of 5 m. Rock loading and transportation in the slot are illustrated in Figure 2-4. The shafts are used for rock hoisting and transport of back-fill material to the slot.

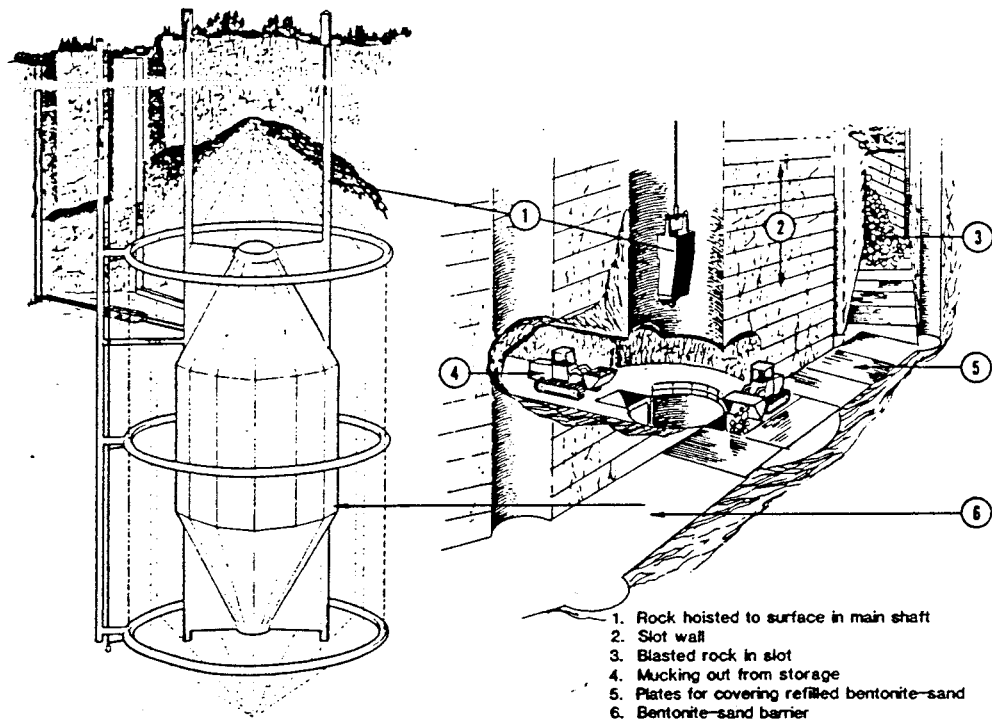

Figure 2-4. Mucking and hoisting of rock.

Detailed mapping of the slot wall is possible because the wall is made visible successively as the excavation advances upwards. A discovery of seeping water should indicate that a passage is opened through the hydraulic cage. By measurements in the hydraulic cage and supplementary drilling such transportation paths can be intersected.

The excavation of the inner repository is preferably carried out in parallel with the excavation and back-filling of the bentonite/sand barrier. Then a much more simple way of loading and hoisting of the rock can be arranged compared to the way when excavation of internal drifts and shafts is made later.

In two places, communication routes will have to be opened through the bentonite/sand slot. These routes are for transport of fuel canisters into the repository and for air transport in the heat exchange system combined with personnel passage and material transports into and out from the repository. Special care will be paid to these openings when the repository is to be sealed off.

2.5.3 Farm of WPCs

The prime planning of the Swedish system is to dispose all the spent fuel in one place. This means for the WPC concept that seven caves should be located close to the central shaft system.

In the course of the study a co-location of several caves was discussed. The main objective was to simulate some plausible situations from an excavation and rock mechanics point of view. Therefore, the characteristics of the well studied rock at Forsmark was chosen /Christiansson et al., 1987/.

Figure 2-5 shows how five WPCs could be placed in the rock. No risks for caving during construction of the slot were identified when analyzing possible movements of rock boulders in relation to the occurrence and nature of existing fracture systems.

On a theoretical basis, when not considering the SFR rock characteristics specifically, seven WPCs could be located within an area with a diameter of about 1000 m in the horizontal plane. Six WPCs are hereby placed in a polygon at a centre distance of 450 m and one WPC in the middle.

2.5.4 Depth Below Surface

The depth below the surface of the WPC has been proposed to be 200 m for the top part of the bentonite/sand barrier.

Generally the upper 100—150 m of the bedrock is set through by joints and faults to such an extent that it is not considered advisable to use these parts for the construction. Furthermore, it can not be excluded that an aerobic chemical environment is prevailing in this upper part. This would be negative with respect to the retardation of migrating radionuclides. The 200 m depth is assumed to be satisfactory.

The 200 m depth is also assumed to be satisfactory when considering possible glaciation effects and protection against military weapons.

2.5.5 Sealing of Repository

When in the future the decision is taken to abandon the repository necessary steps for sealing-off are taken.

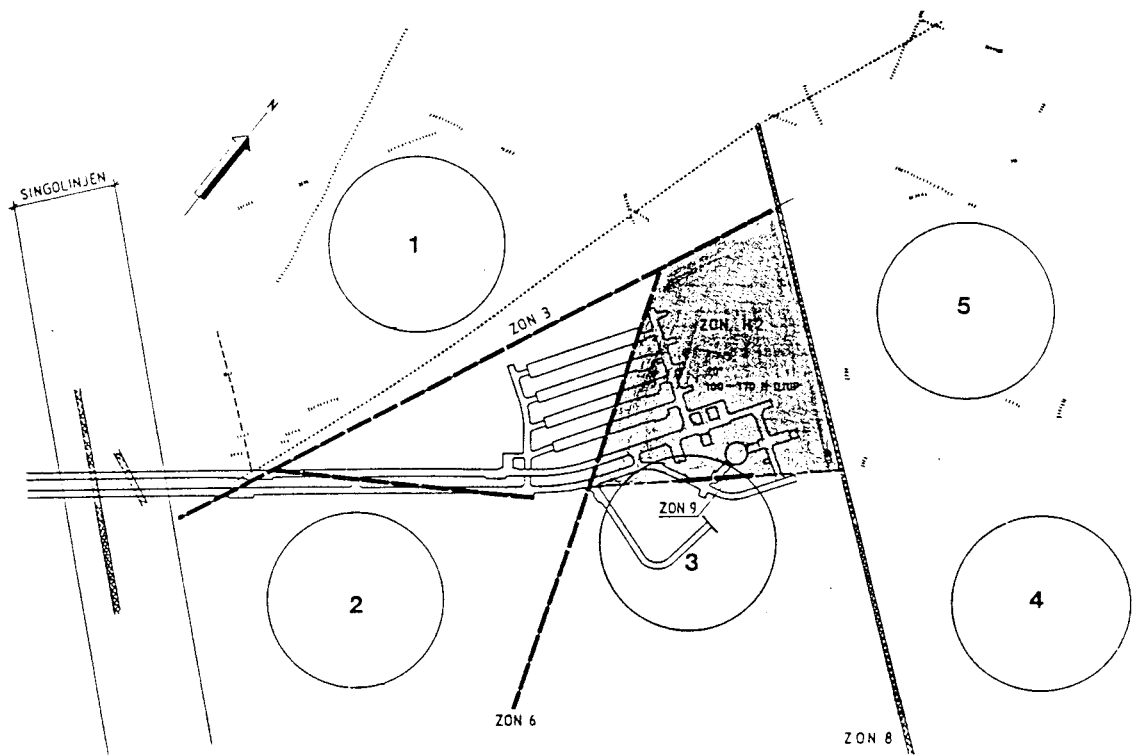

Figure 2-5. Example of locating several WPCs at one site. The exemplified site is SFR. Outer contours of WPC represent the hydraulic cage.

After evacuation of unnecessary equipment and material inside the bentonite/sand barrier, all openings are back-filled with finely ground rock and water. The gain is that the chemical environment may be well defined and that the walls of the excavated canister channels, drifts, and shafts are supported. The canisters and their contents of fuel elements are stabilized in the canister channels. The crushed rock also has the property of sorbing nuclides.

It is considered most advantageous if the back-fill is fine enough to provide a barrier against fast transportation of nuclides to the outer parts of the interior. For this a particle size of 10^{-4} m should be sufficiently fine.

Such fine back-fill is widely used in mines all over the world. The re-filling of mined areas is one way of disposing the tailings, i.e. the waste from the mineral separation process. Some mining methods also rely on back-filling as a way of stabilizing the walls of the stopes. In the mining industry the aim is to use a back-filling material with as high a water drainage velocity as possible. Therefore the finest part of the tailings is separated prior to sending the material back to the mine. Still, in Sweden today back-fill is used that has a $k_{80} = 10^{-4}$ m, that is 80% by weight of the material is finer than 10^{-4} m. About 20% by weight is finer than $2 \cdot 10^{-5}$ m. A finer material is possible to use in the WPC with the same re-filling method. The smallest particle size to be used has, however, not been determined.

The back-filling technique used in the mines is to mix the filling material with water to a mixture containing 60—70% by weight of sand. This mixture is pumped in pipes to the place of re-filling. The drainage rate of the mixture decides how the barriers for water separation are to be arranged. In the case of fine sand the main part of the water is recovered as overflow, while only minor parts are received in the bottom section of the re-filled area.

The water level inside the bentonite/sand barrier will thereafter sink somewhat, when the gradient forces the water to penetrate the bentonite/sand also in the direction from the inside of the walls. The water level, however, is not considered to sink below the uppermost canister in the repository.

The natural water filling of the hydraulic cage is a process which has been estimated to take about 50 years in the normal case with the ground water flow observed at sites possible for a final repository /SKN Report 16, Chapter 14, 1985/.

2.5.6 Temperature Conditions

As soon as the disposal of the spent fuel starts, the temperature of the air will increase to the design limits of 40°C in the air leaving the heat exchanger (circulating down in outer ventilation shafts) and 60°C in the air rising in the inner ventilation shafts.

The temperature in the bentonite/sand barrier will during the first one hundred years increase with about 15—20°C, from about 10°C to about 25—30°C.

Due to the heat generated by the fuel the temperature of the repository will rise to above 100°C after closure. In the Reference Alternative the capacity has been limited so that the temperature in the repository will rise at most to 150°C.

Within 50 years after closure a maximum temperature of 80°C is reached in the bentonite/sand barrier. This temperature, which has been used as a design limit when determining the distance between the inner part of the repository and bentonite/sand barrier, is judged not to affect the chemical and physical properties of the bentonite/sand barrier.

About 200 years after closure the temperature reaches a peak of about 30°C in the rock mass where the hydraulic cage is situated.

If the repository is supervised and monitored for a longer period than 100 years the maximum temperatures will decrease, but very slowly with increasing time.

3 LONG-TERM FUNCTION OF REPOSITORY

This chapter presents the function of the repository from the time the canisters collapse. The descriptions point out the major questions affecting the nuclide release in the long run. Finally the selected scenario for evaluation is summarized.

3.1 GENERAL

The life of the repository can roughly be divided into two phases: the initial operating/monitoring period and the long-term period from sealing and onwards. The dissolution and migration of radionuclides in the long run are affected not only by the situation in the future but also by events occurring during the initial phase. Such events are related to maltreatments in repository construction, canister handling, etc., and are controlled by Quality Assurance. In this study, therefore, the basis has been that the repository, when sealed off, fulfills established quality criteria.

The presentation is concentrated on the time after the canisters are assumed to have collapsed.

3.2 FUNCTION OF REPOSITORY

When the repository has been abandoned after sealing, the ground water table relatively quickly recovers to its original level. The bentonite/sand barrier saturates and swells. The interior parts of the repository are completely filled up by water entering through the barrier. The temperature rises and the inner rock mass expands.

About two hundred years after sealing the temperature has reached its peak values inside as well as in the neighborhood of the repository.

3.2.1 Fuel and Canisters

Under anaerobic conditions the wall thickness of the canister is designed to stand against breakthrough for 1 000 years, see Chapter 7. With respect to the difficulties in determining the corrosion resistance of the welding seam, a canister life-time of 200 years has been conservatively assumed.

All canisters are assumed to collapse instantaneously. The water penetrates the canisters and the fuel is immediately surrounded by the water. The dissolution process starts.

Since the fuel is young the radiolysis of water is considered to be one major factor affecting the rate of fuel dissolution.

The elevated temperature (150°C) gives rise to an increased uncertainty in the determination of the rate of dissolution of nuclides, since the thermodynamic equilibrium data for important radionuclides are known at room temperature only.

Some nuclides will have a low solubility limit under oxidizing conditions, for example Pu. When the fuel matrix is dissolved, parts of the inventory of these nuclides are transferred to the water in colloidal form.

The iron in the canisters is anticipated to provide a reducing environment outside the canisters as well as inside, except in a thin zone near the fuel surface. The canisters will corrode under reducing conditions and produce hydrogen gas. The Fe corrosion product can act as a sorbent for radionuclides.

By taking the measure of back-filling shafts and canister channels with finely ground rock and water at sealing off, the corroded canisters and the fuel can be assumed to remain in the initial storage position.

3.2.2 Canister Channel

The canisters are surrounded by a finely ground rock material, which is considered to reduce thermally induced circulations in the canister channels and in the shafts.

The nuclides escaping out through the canisters diffuse through the back-fill to fissures in the rock mass surrounding the canister channels. Colloids are assumed to be trapped in the back-fill.

3.2.3 Interior Rock Mass

The nuclides migrate through the interior rock mass in fissures, which mainly have been formed during the excavation. Surfaces are available for sorption but the fissures also provide paths for water to circulate. During the period when the thermal power is in force an effective water circulation is expected. Thus the nuclides migrate rapidly through the interior rock mass.

3.2.4 Bentonite/sand Barrier

The bentonite/sand barrier is designed for isolating the interior rock mass from the outer rock mass. The aim of the design is to:

- Obstruct water to flow through the barrier;
- Sorb nuclides and thus to prolong the initial transient migration phase.

In addition to this the bottom part carries the load of the interior rock mass.

Due to the thermal expansion of the rock mass initially, displacements of the interior into the bentonite/sand barrier will occur. During cooling off the inverse process takes place, whereby the bentonite swells and fills the increasing slot.

The hydrogen gas, which is produced from the corrosion of steel canisters and liners, is collected in the top part of the WPC, where it escapes out through the bentonite/sand barrier.

The nuclide transport through the barrier will occur by diffusion and by natural and thermally induced flow.

A temperature limit of 80°C is considered for the bentonite in order for it to maintain its good physical and chemical properties.

3.2.5 Rock Mass from Bentonite/sand Barrier to Hydraulic Cage

Outside the bentonite/sand barrier the nuclides diffuse in the stagnant water in the fissures closest to the barrier. Further out the water is in motion and transports the nuclides to the hydraulic cage. Sorption occurs on the walls of the water conducting fissures.

The rock mass closest to the bentonite/sand barrier has a low hydraulic conductivity during the period with elevated temperature. This is caused by the heat expansion of the rock mass and creates a resistance against the thermally induced ground water flow through the repository.

3.2.6 Hydraulic Cage

Once in the cage the nuclides are mixed in the total volume of water in the cage.

The function of the cage is to divert the natural ground water past the outside of the repository. The efficiency is dependent on the fracture characteristics of the bedrock. If the ground water flow is very distinctly distributed on a few channels, the effect of the cage is that the flow passing through the cage is unchanged with respect to velocity. It is only the total volume of water that is decreased. On the other hand if the ground water flow is evenly distributed in the bedrock, the velocity is decreased evenly in the water passing through the cage. These questions are discussed in Chapter 12.

Outside the cage the regional ground water flow is affected by the cage. The structure will increase the natural gradient just outside and attract more water than otherwise would have passed the rock mass with no cage present. This mainly affects the transportation from the cage to the surface.

The cage is not expected to have any diverting effect for the thermally induced ground water flow.

In the long-term perspective there is a risk for the drains and annular tunnels of the cage to clog.

3.2.7 Geosphere

The conceptual model of water transport in the bedrock applied in this study is based on water flow in channels, see Chapter 11.

The transportation distance from the cage to the surface is considered to be short. With the cage present it is likely that rapid transportation paths, if existing, will constitute the major links with the biosphere. In case only a few channels provide for the total transportation, then very limited rock surface area is available for sorption.

Reducing conditions are primarily assumed to exist in the geosphere at repository depth. Reducing or oxidising conditions are, however, judged to be of negligible importance to the calculated dose rates to man.

3.2.8 Biosphere

The recipient in the biosphere is either a lake, a well or a combination of both.

The size and catchment area of the well can be dependent on the shape of the repository and depth of the location of the repository.

3.3 SELECTION OF SCENARIO FOR EVALUATION

In summary the selected scenario for evaluation is based on:

- Mild steel canister with a short life time;
- Fuel dissolution determined by radiolysis and solubility limitations in reducing environment;
- Back-filling of finely crushed rock in excavated openings in the repository in conjunction with sealing off;
- Maximum temperature in the repository limited to 150°C and in the bentonite/sand barrier to 80°C;
- No resistance to nuclide migration of significance in the rock mass between the canister channel and the bentonite/sand barrier;
- Totally surrounding bentonite/sand barrier;
- Thermally induced ground water gradient directed upwards, decreasing with time;
- Hydrogen gas escaping through the bentonite/sand barrier without causing any additional releases of nuclides from the near field;
- Ground water transport in channels in the bedrock.

The hydraulic cage is studied separately.

4 TEMPERATURE DISTRIBUTION

The model presented was developed for the calculation of the temperature close to the surface of the canisters in the back-filled canister channels. Different ways of decreasing too high peak temperatures are analyzed.

4.1 GENERAL

Calculations on the temperature field were made for the case where all openings would be left unfilled at sealing /SKN Report 16, Chapter 13, 1985/. The canister channels were each considered to have three canisters in a row. The temperature at mid-height of the repository is seen in Figure 4-1.

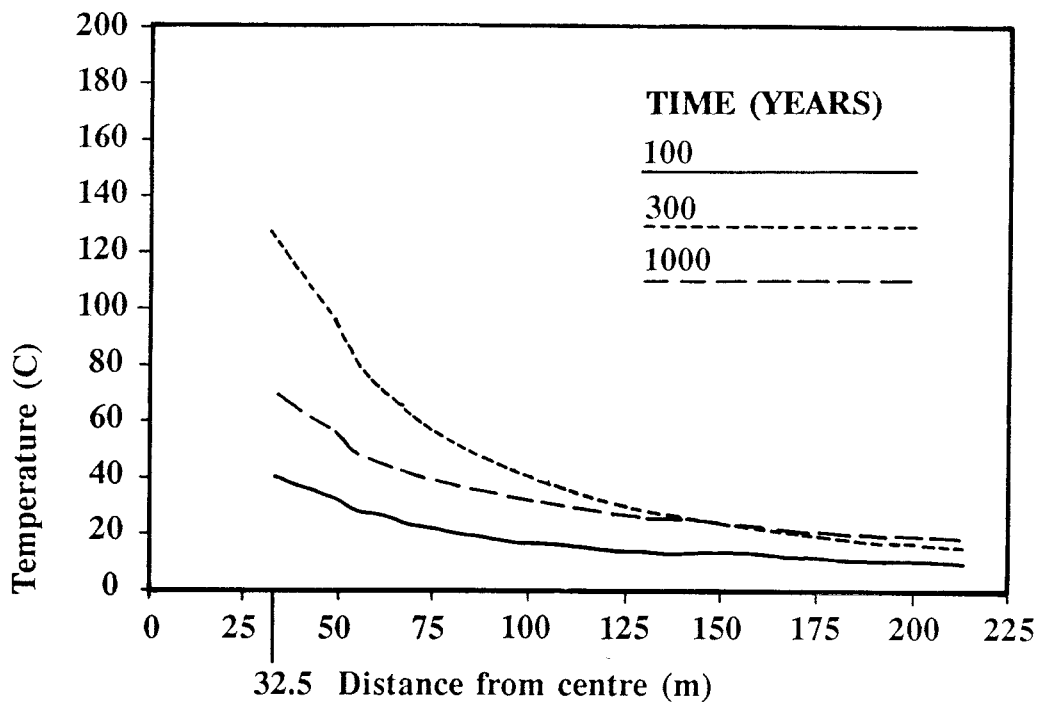

Figure 4-1. Calculated spatial temperature variations along a horizontal line located at mid-height of repository.

4.2 TEMPERATURE DISTRIBUTION WHEN CANISTER CHANNELS ARE FILLED WITH FINELY GROUND ROCK AND WATER

In the course of the present performance analysis one measure chosen was the back-filling of all openings in the repository with finely ground rock and water. In this case the fine back-fill should have a low hydraulic conductivity so that the water circulation in the back-filled channels is negligible. This in turn means that the decay heat from the fuel will be transferred to the surrounding rock by conduction only.

The temperature distribution has been computed numerically by the use of a three dimensional finite element model and the code SOLVIA-TEMP /SKB, 1989/. Cylindrical symmetry is used, thus assuming an infinite number of canister channels stacked above each other. This results in a high order of symmetry and only a small part needs to be modelled. The chosen part, see Figures 4-2 and 4-3, comprises 1/24 of one conical level containing a half of a canister channel and a half of the rock mass surrounding the channel. The outer ranges of the model correspond to the location of the bentonite/sand barrier.

The assumption applied in the calculation is that at time zero (0) spent fuel, interim stored for 40 years, is placed in the repository. The virgin temperature in the rock mass is set to 10°C. During the one hundred years of ventilation the temperature rises to the limit of 60°C in the inner shafts and to 40°C in the outer shafts. The repository is quickly back-filled and sealed off. Input data used are presented in Table 4-1.

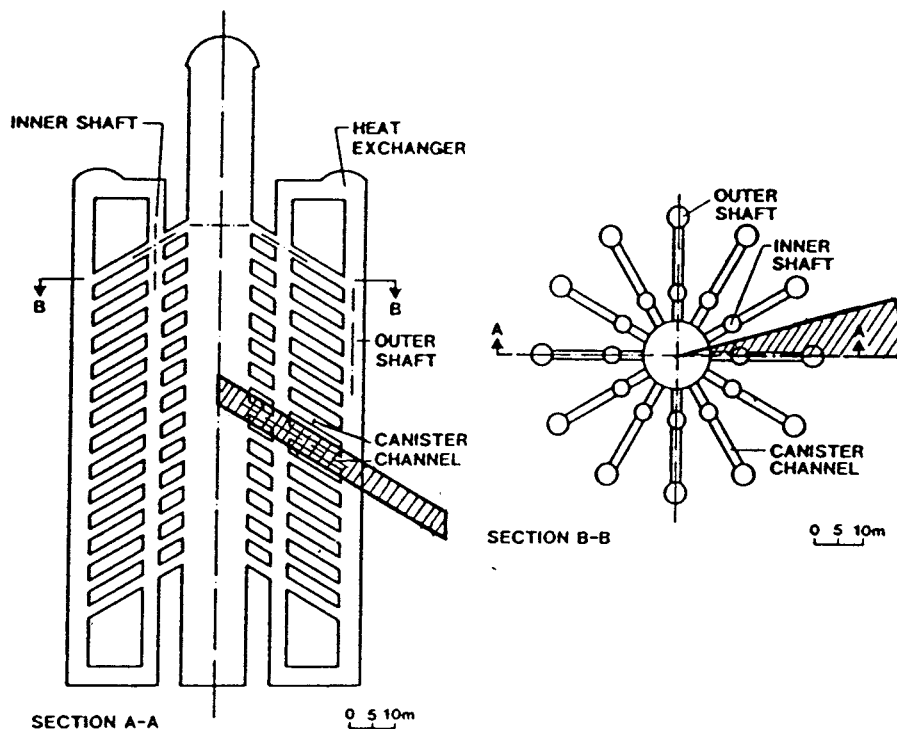

Figure 4-2. The location of the part modelled.

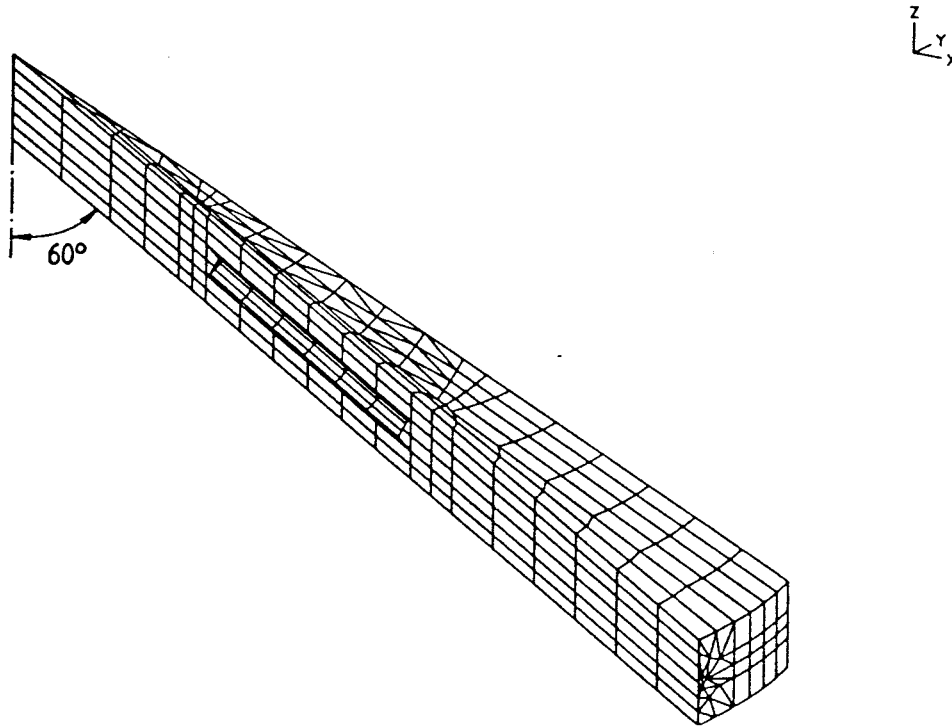

Figure 4-3. Three-dimensional finite element model used. The figure is plotted using the so-called "hidden lines" concept. Note the 30° slope of the model from the horizontal plane. The outer radius of the FE-model corresponds to the bentonite/sand slot.

The canister channels were assumed to host three canisters. The received peak temperatures at different places along the canister channels are presented in Figure 4-4. The computed maximum temperature is 250°C, obtained at point B about 50 years after the closure of the repository. This temperature as well as other maximum temperatures calculated are believed to be 20—30°C too high depending mainly on two sources:

- The assumption of infinite level stacking at heat from the distant non-existing levels. Comparison between two simple one-dimensional analytical models, one with cylindrical and the other spherical symmetry, suggests that this error is about 20°C;
- The canisters are not included in the model, leaving a cavity which gives the model too low thermal conductance near the canisters.

The computer code is very accurate. The calculated temperature field is considered to be estimated within an accuracy of $\pm 5^\circ\text{C}$ at all points. For the error estimation reference is made to /SKB, 1989/.

Table 4-1. Data used in the calculations.

Geometry data

* Central shaft:	diameter 14 m
* Inner ventilation shafts:	diameter 2 m centre 13 m from the cave axis
* Outer ventilation shafts:	diameter 3 m centre 30.5 m from the cave axis
* Bentonite/sand barrier:	50 m from the cave axis
* Canister channels:	diameter 1.7 m slope 30° from horizontal plan radially outwards
* Canisters:	three per channel combined length 16 m diameter 1.3 m
* Vertical pitch:	5.43 m (3 m rock orthogonally between channels)

Material data

* Rock:	thermal conductivity $3.35 \text{ W} \cdot \text{m}^{-1} \cdot \text{K}^{-1}$ specific heat $2.16 \text{ MJ} \cdot \text{m}^{-3} \cdot \text{K}^{-1}$ density $2700 \text{ kg} \cdot \text{m}^{-3}$
* Ground rock/water:	thermal conductivity $2.1 \text{ W} \cdot \text{m}^{-1} \cdot \text{K}^{-1}$ specific heat $2.8 \text{ MJ} \cdot \text{m}^{-3} \cdot \text{K}^{-1}$ density $2190 \text{ kg} \cdot \text{m}^{-3}$

Fuel data

8.55 tonnes of PWR fuel per canister:

* Specific power	$38.5 \text{ W} \cdot \text{g}^{-1}$ ¹⁾
* Burn-up	$38 \text{ GWd} \cdot (\text{tU})^{-1}$
* Enrichment	3.2%

1) Decay curve according to KBS-3 /1983/.

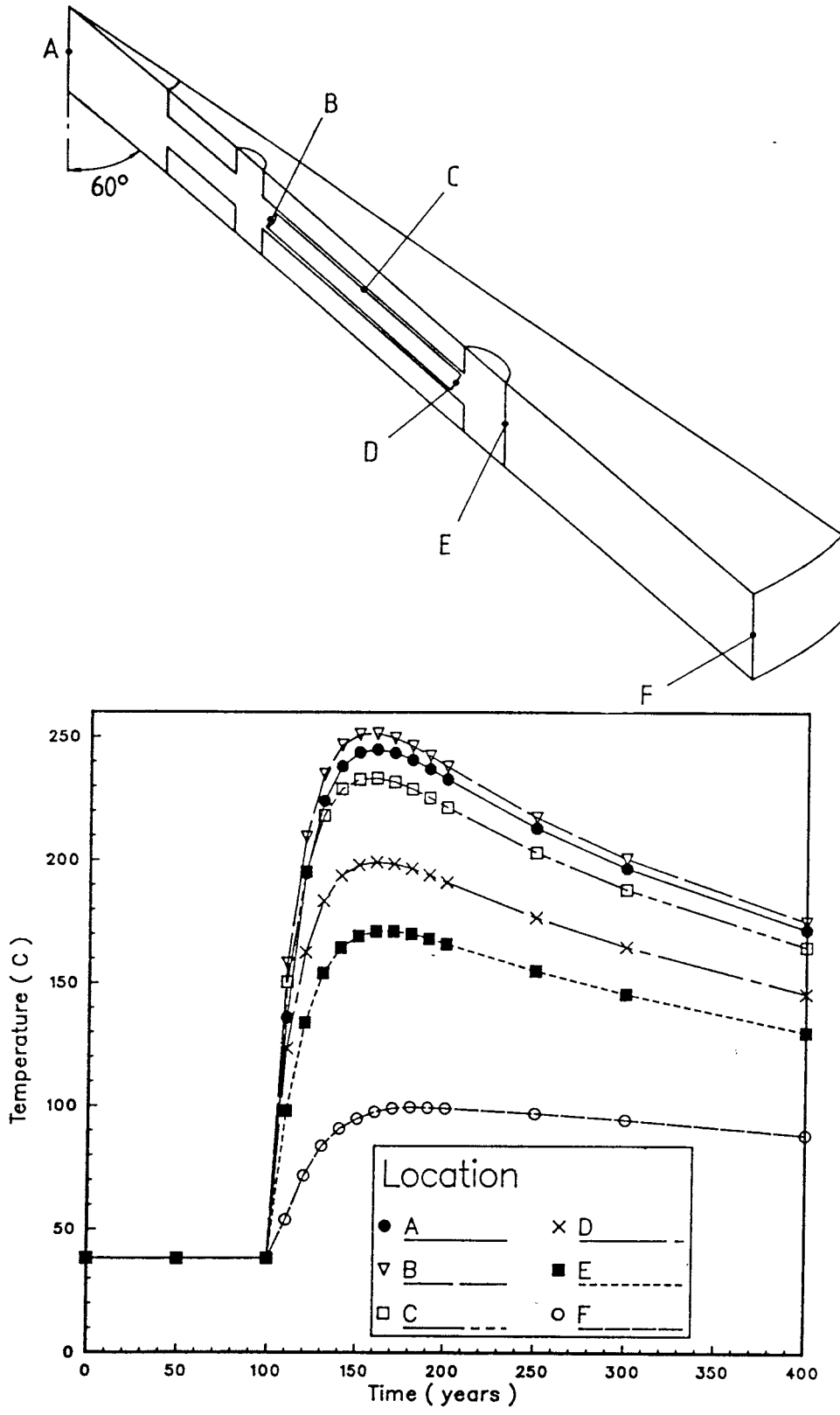

Figure 4-4. Calculated temperature inside the bentonite/sand barrier at different locations marked in the drawing (top). The bentonite/sand barrier is at location F.

Time 0 (zero) denotes the time the canisters are placed in the repository. Prior the fuel is assumed to have been interim stored for 40 years.

4.3 MEASURES TO MEET PEAK TEMPERATURE OF 150°C

In order to analyze the options available for decreasing the peak temperature on the canister surfaces to about 150°C a simple one-dimensional heat flow model was adapted. This model approach is based on the fact that the temperature (minus the surrounding temperature) is proportional to:

- Dissipated canister power;
- The inverse vertical distance between channel levels.

Furthermore, the heat flow outwards and the temperature are nearly uniform at a couple of meters outside the canisters. The heat flow density and the temperature vary but only with the radius from the outer ventilation shafts and outwards. The error in this simplified calculation is considered to be only a few degrees C.

In Table 4-2 the results for different modifications of the design are presented.

Table 4-2. Reduction in peak temperature for different modification alternatives.

Modification alternative	At location B in Figure 4-4 estimated temperature °C/	
	Maximum	Reduction
2 canisters per channel (the innermost removed)	155	-95
Level thickness increased by 50% (to 8.15 m vertical pitch)	170	-80
Canisters moved outwards 10 m (along with the shafts)	180	-70
Canisters moved outwards 15 m (along with the shafts)	155	-95
Canisters moved outwards 25 m (along with the shafts, the barrier moved further out)	115	-135

The estimations are, like the computed results (just outside the canister surfaces), probably 20–30°C too high due to model imperfections.

In order to be able to maintain the outer dimensions of the design of the repository /SKN Report 16, 1985/ the temperature requirement was chosen to be met by a reduction of spent fuel stored in each canister channel. A reduction to only two canisters per canister channel with the innermost one removed decreases the maximum temperature to the required level. The impact on the WPC analysis by such an action is seen only in the cost estimates; more caves are required. Instead of five caves seven are needed for the Swedish program.

4.4 CONCLUSIONS

In order to limit the maximum temperature on the canister surface to 150°C the capacity of spent fuel in one cave has been limited to 1100 tonnes of U.

5 BUFFER MATERIALS AND MIXTURES

In this chapter the requirements of the barrier and back-fill material are discussed. The qualities that are possible to achieve in different parts of the barrier are viewed based on present knowledge of properties of different bentonite/sand mixtures.

5.1 GENERAL

One very important barrier in the WPC-concept is the barrier separating the interior part from the outer rock mass. Its aim of function is two-fold:

- To obstruct water from flowing through the central repository so that the nuclide transport through the bentonite/sand barrier by flowing water is negligible compared to transport by diffusion;
- To provide a barrier against flow of water to such an extent that the “diffusion resistance” against nuclide transport from the barrier to the flowing water outside is developed.

In addition the top part of the barrier should also have the ability to allow hydrogen gas produced from the steel corrosion to migrate out to the surrounding rock mass.

5.2 BENTONITE/SAND BARRIER

The buffer material is to consist of a mixture of bentonite clay and quartz sand. Bentonite clay is acknowledged to have the good properties required for the barrier with respect to swelling, low hydraulic conductivity, good thermal conductivity, long-term stability, and high nuclide sorption capacity. The basis for choosing this material is the same as for the KBS-3 concept. The quartz sand is also chosen in accordance with the definitions for buffer materials outlined in the KBS-3 study. Quartz is a chemically well defined material, which has very beneficial properties of thermal conduction.

The properties of bentonite and mixtures of bentonite and quartz, respectively, are well known through a number of studies and reports. No new studies on material properties have been initiated in the course of the present study. All data used in the safety analysis have been compiled from different references. The view on the buffer materials is only discussed here against the background of those requirements that are very specific to the WPC.

The barrier can be divided into three separate parts:

- Bottom cone;
- Cylindrical part;
- Top cone.

These parts have different functions limiting the range of bentonite contents to be used in the different mixtures.

5.2.1 Bottom Cone

The bottom cone is to carry the total load of the interior rock mass after completion of the slot excavation, which puts the focus on the structural stability of the back-fill in that part. The back-fill is to prevent the rock mass from sinking due to gravity into the slot through the back-fill. This eliminates the risk for the inner rock mass to come into contact with the outer rock mass. Furthermore, the back-fill shall also limit the settlement of the inner rock mass as much as possible. These requirements call for a mixture of bentonite and sand with a high proportion of sand. Pure bentonite might under the mentioned circumstances be plastic in such a way that the bentonite is pressed upwards in the slot by the weight of the inner rock mass.

The approach has been to choose a mixture with as low bentonite content as possible because the stability improves with the increased proportion of sand. The result of the SKN study /SKN Report 16, Chapter 6, 1985/ was that a mixture with 10% bentonite should have satisfactory swelling properties, while a mixture with only 5% bentonite was considered doubtful to suggest, since this mixture would contain a theoretical minimum of bentonite which could not stand any uneven distribution of the bentonite in the mixture. The maximum content of bentonite, that can be tolerated, was not analyzed.

Laboratory tests on compression, mixing, and swelling indicated that the 10% bentonite mixture should be able to be compressed in the slot with a rather high density of about 2.2 tonnes per m^3 in dry conditions, which is sufficient for reaching a hydraulic conductivity of 10^{-10} to $10^{-11} \text{ m} \cdot \text{s}^{-1}$. With laboratory equipment the best result obtained for a 10% bentonite mixture was $10^{-9} \text{ m} \cdot \text{s}^{-1}$. One reason is that compression in the laboratory scale was not possible to make as effectively as is assumed to be the case in the slot. It is further considered possible to improve the mixing of bentonite and sand and to use a more favourable grain size distribution in the full scale. It is doubtful if the hydraulic conductivity can be decreased significantly by the use of a somewhat richer bentonite mixture.

The mechanical response of a 10% bentonite mixture in the bottom cone is measured to be such that the inner rock mass can be expected to settle at least 100 mm and probably 200 mm. This settlement has been judged to be acceptable from the excavation point of view.

5.2.2 Cylindrical Part

The guiding rule in the design of the bentonite/sand barrier has been to decrease the hydraulic conductivity of the barrier upwards, in order to compensate for the increase in hydraulic conductivity in the surrounding bedrock. The basis for this rule is that the hydraulic conductivity in the bottom cone is sufficiently low.

With the aim of reaching a hydraulic conductivity of 10^{-10} to $10^{-11} \text{ m} \cdot \text{s}^{-1}$ in the cylindrical part it is assumed convenient to reach the lower value if the bentonite content is increased to 20%, which so far has been considered for this part of the slot. No technical obstacle exists against increasing the bentonite grade in the cylindrical part of the slot.

5.2.3 Top Cone

The top part is, if the hydraulic conductivity of the bedrock adapts to the common rule of increased conductivity with decreased depth below surface, situated in the most permeable rock. Thus the hydraulic conductivity in this part of the

slot should be the lowest. In addition the top cone has a sensitive position in the structure. During heating the inner rock mass will expand and compress the top cone (as well as other parts of the barrier). But at cooling off and shrinking the swelling pressure in the bottom cone will not be sufficient enough for lifting the central rock mass. Thus the shrinkage will result in a widening of the barrier in the top cone. This requires a better swelling ability of the material in this part of the barrier than in the bottom part.

Both the need of a low hydraulic conductivity and improved swelling properties call for a higher bentonite content in the top cone mixture. A mixture of 50% bentonite is desired.

5.3 FUNCTION OF BENTONITE/SAND BARRIER

One quality criterion for the bentonite/sand barrier is that it shall provide such a low hydraulic conductivity that the major nuclide transportation mechanism through it is by diffusion. For the normal natural gradient at repository depth a hydraulic conductivity of 10^{-10} to 10^{-11} $\text{m} \cdot \text{s}^{-1}$ should be satisfactory for preventing significant nuclide releases through the bentonite/sand barrier by flow, especially when considering a decrease of the natural gradient over the bentonite/sand structure due to the presence of the hydraulic cage. But, as is presented in Chapter 10, the thermal load induces a gradient which might create a substantial flow. Although this flow is limited in time, it has a very important effect on the release rate of nuclides.

The bentonite/sand mixture has good sorption properties for many of the nuclides. Any colloid that may escape through the finely ground rock material around the canister is not expected to be able to migrate through a homogeneous bentonite/sand barrier. Additional releases to releases by diffusion and the initial thermally induced flow can be caused by:

- Hydrogen gas break-through in the top part of the bentonite/sand barrier;
- Cracking of cemented bentonite/sand so that connections are opened through the whole thickness of the bentonite/sand barrier.

No detailed performance analyses have, however, been performed on these topics.

5.4 DIFFUSION RESISTANCE

In case of a low water flow through the bentonite/sand barrier the nuclides outside the barrier will diffuse through stagnant fissure and pore water in the rock closest to the barrier and further out to the flowing water in the fracture systems in the rock between the hydraulic cage and the bentonite/sand barrier. This transfer of nuclides from the outer boundary of the barrier to the flowing water is a slow process which in addition is further slowed down as the water front advances forward along the bentonite/sand barrier. The process is illustrated in Figure 5-1. The result is an important barrier function created in the rock mass closest to the bentonite/sand barrier, a barrier function called "diffusion resistance".

In the case of diffusion through the bentonite/sand barrier as the only important release mode (no significant addition to the release rate by advection) the "diffusion barrier" is much more important than the bentonite/sand barrier. Ad-

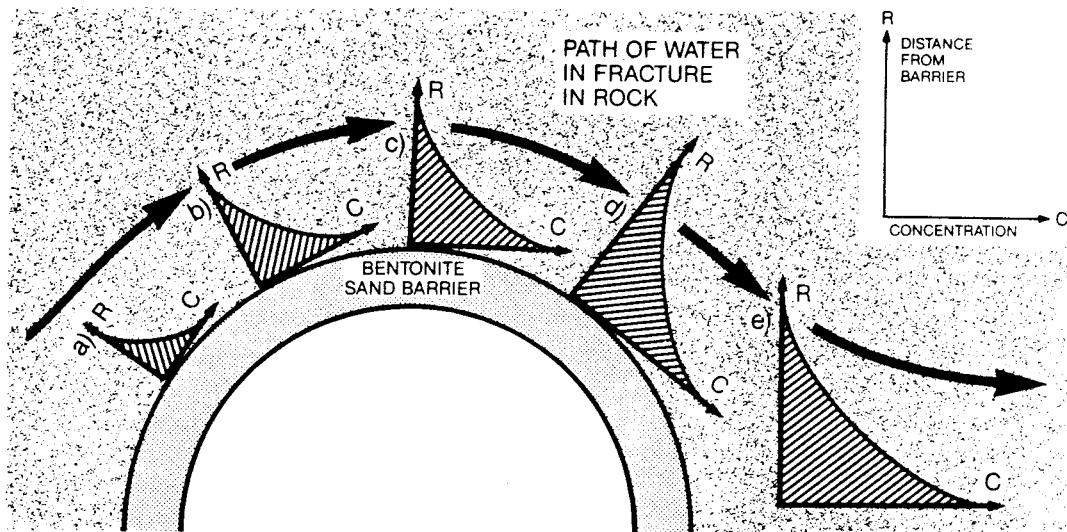

Figure 5-1. The water passes the bentonite/sand barrier as is shown by the black arrows. At a) nuclides escaping from the barrier have got into contact with the water and have reached a short distance out into the water. At b) the nuclides have diffused farther out into the water. The concentration closest to the bentonite/sand barrier has increased. During the progressively longer contact time c) and d) the concentration closest to the bentonite/sand barrier increases further. The concentration in the water farther out also increases. As the difference in concentration is the driving force for diffusion, the transportation of nuclides out into the water will be lower at d) than at a).

vective transport through the bentonite/sand barrier will, however, neutralize the “diffusion resistance”.

5.5 HYDROGEN MIGRATION

5.5.1 Through Bentonite/sand Barrier

Contradictory to the desire of providing a low hydraulic conductivity in the top cone, the question of hydrogen gas migration through the slot requires a sufficiently high gas conductivity. A basic parameter in gas migration is the volume of gas produced. In the SKN study /SKN Report 16, Chapter 11, 1985/ a span of 3 500 — 74 000 Nm³ was considered possible from the available data on steel corrosion. The highest value corresponds to a corrosion rate of 150 μm, a rate that would lead to a total conversion of the 10 mm thick liners in about 35 years time (corrosion on both sides of the liner). Thereafter only about 5% of the initial steel surface area is available. An up to date estimate of the corrosion rate is made in Chapter 7. It concludes that the very conservative assumption of high corrosion rates is very unlikely. A lower rate is most plausible, which then will result in a longer duration time.

The mechanism for gas flow is that the gas starts to flow through the bentonite/sand barrier when a critical pressure for gas flow is reached, a pressure which is dependent on the swelling pressure of the bentonite/sand mixture. For

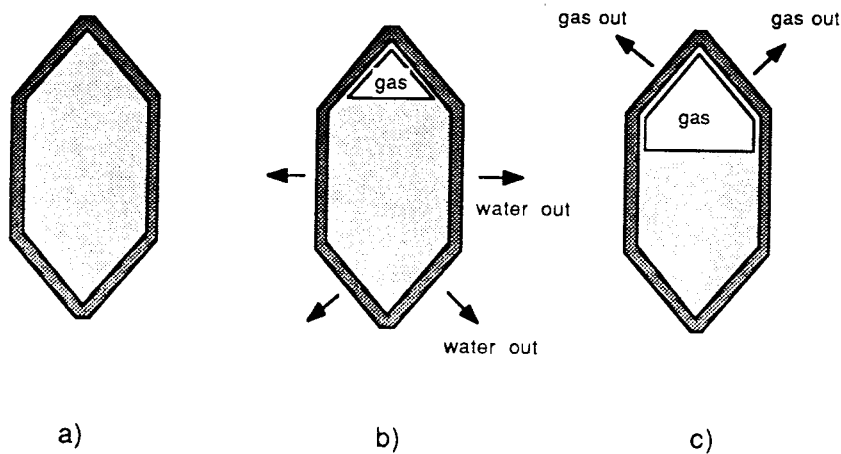

Figure 5-2. Evolution of water and gas flow in the repository.

a) Repository is filled with water.

b) Overpressure is less than the critical pressure for gas flow. Water is expelled.

c) The critical pressure for gas flow has been reached. Gas escapes.

a mixture with 50% by weight of bentonite the critical pressure is between 0.5 and 1.5 MPa (swelling pressure is between 1.0 and 2.0 MPa). The critical pressure drops to about 0.1—0.3 MPa and 0.05—0.1 MPa, respectively, when the bentonite content is decreased to 20% and 10%, respectively. The absolute pressure in the gas at break-through is then the sum of the critical pressure and the hydrostatic pressure at the specific depth.

A high pressure in the interior part of the repository may create a problematic situation. Before the critical pressure is reached a gas cushion is built up and the corresponding volume of water is expelled through the bentonite/sand barrier. When break-through occurs the gas pressure in the cushion is reduced and water may flow back into the repository. This process is schematically shown in Figure 5-2. A cyclic flow of water out through the bentonite/sand barrier may thus develop leading to an increased release rate of radionuclides from the near field.

A more probable sequence of event, based on results of laboratory experiments, is that different channels exist in the bentonite/sand barrier which have different opening pressures. An increased number of channels open as the gas pressure increases and they close successively as the pressure drops. Instead of a cyclic gas flow a more even flow is obtained, a kind of steady state. This will be determined by the relationship between the critical pressure, the gas conductivity of the barrier, and the water level. The stable water level has been calculated for some sets of parameters /SKB, 1989/, see Table 5-1.

Table 5-1. Hydraulic gradient for a given gas flow with a given gas permeability.

Gas flow $\text{Nm}^3 \cdot \text{a}^{-1}$	Gas permeability $\text{m} \cdot \text{s}^{-1}$	Hydraulic gradient $\text{m} \cdot \text{m}^{-1}$	Water level relative to the top m
2 000	$1 \cdot 10^{-16}$	0.16	- 0.8
74 000	$1 \cdot 10^{-16}$	1.5	- 7.5
2 000	$1 \cdot 10^{-17}$	0.75	- 3.8
74 000	$1 \cdot 10^{-17}$	4.08	-20.4

The dilemma with respect to the gas production is if the hydraulic conductivity of the bentonite/sand barrier is decreased in order to prevent thermally induced flow through the top of the repository. The critical pressure then rises and may cause a lowering of the water table so that the canister channels are dried. Then an uncontrolled corrosion environment may develop in the canister channels, especially in the environment close to the water table.

5.5.2 Influence of Outer Rock Mass

The mechanism of gas flow outside the bentonite/sand barrier is different from the mechanism of flow in the bentonite/sand mixture. From experiments and measurements in full scale compressed air storages it is understood that gas entry into rock fractures occurs if the air pressure increases to a pressure close to that of the abundant groundwater. The entry is determined by the capillary pressure characteristics of the fracture mouth /Lindblom, 1988/, but the capillary retention effect of fractured rock is much less than that of the assumed bentonite/sand mixtures. Therefore, once the gas has passed through the bentonite/sand it will continue to enter into and migrate in the existing fractures in the rock. The rate of gas migration is considered to be a function of the conductivity of the rock mass for water and hydrogen and of the flow porosity of the interconnected fracture network.

A study, based on simple models in order to outline the importance of the process and capacity of gas flow in rock, has presented a scenario for flow of the gas from a WPC repository /Lindblom, 1988/. It is concluded that in a low conductive good quality rock mass the evacuation capacity of the rock may be too small for evacuation of the gas produced in the short run as well as in the long run. In such a case a steady-state condition is probable to develop with the water table in the repository stabilized on a level where so much steel is submerged in water that the hydrogen production from corrosion is equivalent to the rock mass discharge capacity. If the water level rises, more steel is submerged and the hydrogen production increases. Thus the gas pressure increases and suppresses the water table downwards until a balanced hydrogen production rate once again is reached.

The height of the gas cushion is dependent on the properties of the rock and, of course, on the hydrogen production rate. If the gas evacuation capacity is too low and the water table is suppressed to a level below the top canisters, then the dilemma of an uncontrolled corrosion process occurs. The extreme is also considered theoretically plausible, that is the rock mass has such a low gas evacua-

tion capacity that the water table is surpressed to the bottom part of the repository.

From the analysis it is concluded that the exact scenario of gas flow and size of gas cushion built up inside the bentonite/sand barrier is of importance to outline. The size of the gas cushion is dependent on the resistance to gas migration in both the bentonite/sand mixture and the rock mass. The gas pressure built up is the sum of the pressure for reaching breakthrough in the bentonite/sand barrier and the pressure for evacuating gas in the rock mass.

In the course of the present study it is assumed that the water table is maintained at a level above the excavated interior parts, thus maximizing the steel surface area exposed for corrosion.

5.6 CONCLUSIONS

The prime value for the hydraulic conductivity of the bentonite/sand barrier is set to $10^{-10} \text{ m} \cdot \text{s}^{-1}$ in all parts of the barrier.

The lowest value judged possible to achieve in full scale compression is $10^{-11} \text{ m} \cdot \text{s}^{-1}$ for a bentonite/sand mixture with 10% bentonite only.

The hydrogen formation calls for a sufficiently high gas permeability in the top part of the bentonite/sand barrier. This is here considered to be achieved in a mixture that has a hydraulic conductivity of $10^{-10} \text{ m} \cdot \text{s}^{-1}$.

6 BACK-FILL AND INNER ROCK MASS

This chapter presents the properties of the back-fill in the canister channels and the rock mass inside the bentonite/sand barrier.

6.1 GENERAL

The virgin pressure in the inner rock mass is relieved by the excavation of the slot. When considering the alternative design with no bottom in the bentonite/sand barrier, Appendix 3, the result is a homogeneous rock mass with a low rock pressure. The other alternative design with a totally surrounding bentonite/sand barrier results in a much more porous structure, since the compression of the bottom part leads to the opening of fissures in the inner rock mass.

In the current study the design considered is the alternative with a surrounding bentonite/sand barrier. Only this alternative is analyzed in this chapter.

6.2 BACK-FILLING

In the SKN study all shafts and canister channels were considered to be left open when the repository was sealed off. After closure ground water would fill all the vacant space in a relatively short time period. In order to stabilize the canisters and the fuel pins in the storage space, as well as to provide an additional rock surface area for sorption, a complementary measure of back-filling with crushed or ground rock is assumed in the current study.

The two alternative back-filling materials discussed are a coarse crushed rock material, which permits the water to circulate in the vertical ventilation shafts as well as in the canister channels, and a finely ground rock material that will prevent water flow and guarantee a radionuclide transportation from the canister to the rock wall of the canister channels by diffusion.

For the initial tentative estimate on nuclide migration two particle sizes of the back-fill were considered and their related water flows calculated:

Particle diameter m	Water flow m³ · m⁻² · s⁻¹
2.5 · 10 ⁻²	2.2 · 10 ⁻⁴
1 · 10 ⁻⁴	3.0 · 10 ⁻⁹

The coarse back-fill lacks the feature of preventing the nuclides from being transported to the outer ventilation shafts by flow. But it provides a larger rock surface for sorption as the nuclides by flow come into contact with the back-fill also in the ventilation shafts. This difference, however, is of minor importance to the release rate of dose important nuclides since the sorption capacity of the bentonite/sand barrier is larger, see Table 6-1.

Table 6-1. Relative sorption capacity in different barriers.

- A: Finely ground rock in canister channels only.
- B: Finely ground rock in all openings.
- C: Rock mass between inner repository and bentonite/sand barrier. Fissure distance of 0.5 m.
- D: Bentonite/sand barrier, 5 m thick.

Values below are relative to the capacity of the bentonite/sand barrier.

Nuclide	A	B	C	D
C	0.005	0.2	0.3	1
Se	0.01	0.4	10	1
Sn	0.006	0.3	10	1
I	0.001	0.05	0.07	1
Pu	0.2	10	300	1
Np	1	50	2 000	1

The time to reach equilibrium in C is:

Se and Sn	$8 \cdot 10^4$ years
Pu and Np	$4 \cdot 10^8$ years

The judgement is that it would be most advantageous if the back-fill is fine enough for providing a barrier against nuclide transportation by advection. The fill with a particle diameter of 10^{-4} m is sufficiently fine for this purpose.

6.3 INNER ROCK MASS

The inner rock mass develops a more porous structure at excavation. The bentonite/sand mixture in the bottom cone will be compressed when the load on that part increases. The existing fissures will in the first hand open. This process is expected to proceed successively as the excavation advances upwards and is most probable to happen in conjunction with the blasting of rounds. As the width of the inner rock mass is in the range of 100 m, the mass will crack and cave along fissure planes due to the gravity force. The exact resulting structure of the inner rock mass is dependent on the original fissure structure of the rock. The impact is caused by the over all tendency that the hydraulic conductivity of the interior parts increases by one to several orders of magnitude compared to the initial conductivity of the rock. The interior part is to be looked upon as a very blocky rock mass.

After sealing the inner rock mass gets warmer and expands in volume. Calculations on the WPC 1100 have shown that the expansion is about 200 mm in the outer diameter of the rock mass. This expansion means that the ben-

tonite/sand barrier is compressed accordingly. The increases in volume reach the peak within 100 years after sealing, that is during a time when the steel canisters still are considered to be intact. During cooling the rock mass shrinks and the bentonite/sand barrier is widened due to the swelling of the bentonite/sand mixture. This process is considered to have no impact in the long run on the release rate of nuclides.

As the temperature in the repository is high (higher than 100°C) during a long time period, the primary minerals may dissolve and form secondary minerals. Silica starts to dissolve in significant amounts when the temperature is above 100°C /Claesson, 1983/. The dissolved silica precipitates when the temperature decreases. Dissolved calcite precipitates when the temperature increases. The effect of dissolution-precipitation of these two minerals may very well be that the hydraulic conductivity of the rock mass decreases, but no such effect has been taken into account in the current safety analysis. The reason is that the dissolution-precipitation processes have been considered to complex to analyze now.

6.4 SORPTION PROPERTIES

The relative maximum sorption capacity for some dose dominating radionuclides, see Subsection 15.4.3, in different parts of the near field is shown in Table 6-1. The dominating barrier for sorption of important fission and activation products in the near field is the bentonite/sand barrier. In reality this barrier is also dominating for actinides, since the time for reaching full sorption capacity in the rock mass is very long in relation to the time for reaching peak release rates. For long-lived nuclides the retardation caused by sorption in the inner rock mass will not reduce the maximum release rate level. For short-lived nuclides the sorption is of much more importance, but none of the short-lived actinides are dose-dominant in comparison with the long-lived actinides, see Table 15-15 in Subsection 15.4.3.

6.5 CONCLUSIONS

The safety analysis is to consider the canister channels to be back-filled with a finely ground rock material.

The interior part has a hydraulic conductivity, which is at least two orders of magnitude higher than the virgin conductivity.

The sorption of nuclides in the interior parts is small in comparison with the sorption in the bentonite/sand barrier.

7 CANISTER AND LINER CORROSION

In this chapter the design of the steel canisters is shown in brief. Thereafter the corrosion environment for the steel is presented and the corrosion rate and hydrogen production at anaerobic conditions estimated.

7.1 GENERAL

The system of barriers in the WPC includes the spent fuel canister which are intended to provide absolute isolation of the fuel during the 100-year dry operational period. The proposed material is mild steel with a wall thickness of 110 mm.

7.2 CANISTER DESIGN

The suggested canister design is shown in Figure 7-1.

The canister consists of a cylindrical part with a bottom and a lid. Fabrication by casting is judged to provide a sufficiently tight canister body.

The lid is equipped with a lifting device for handling of the sealed canister. The lid is to be attached to the cylindrical body by a heat and shrink method, and a final welding seam for sealing.

7.3 100-YEAR OPERATIONAL PERIOD

During the operational period, the WPC will be kept dry and under the foreseen condition the environment for the canister will be very favourable /Marsh, 1985, (Part 1)/.

The radiation from the fuel, that penetrates the canister walls, will initiate the formation of nitrogen oxide and nitric acid by radiolysis of air outside the canisters. Gaseous nitric acid will cause corrosion of the canisters, but only minor quantities of acid are formed and thus the corrosion will be only a few μm /SKN Report 16, Chapter 11, 1985/. The maximum depth of corrosion during a 100 year period for a canister with a wall thickness of 50 mm was calculated to be 3 μm . For a canister with thicker walls the depth of corrosion will tend to decrease, since a lower radiation dose will affect the surrounding air and then the formation of nitric acid.

7.4 AFTER CLOSURE OF WPC

After the operational period the canister channels and ventilation shafts in the repository will be filled with finely ground rock (particle size ca 0.1 mm) and ground water. The total volume to be refilled is 75 000 m³, whereof the water volume is 30 — 40%, or 22 500 — 30 000 m³. The ground water is assumed to be equilibrated with air at atmospheric pressure corresponding to an oxygen concentration of 8 mg·l⁻¹, i e the total oxygen content in the repository is estimated to be 180 — 240 kg.

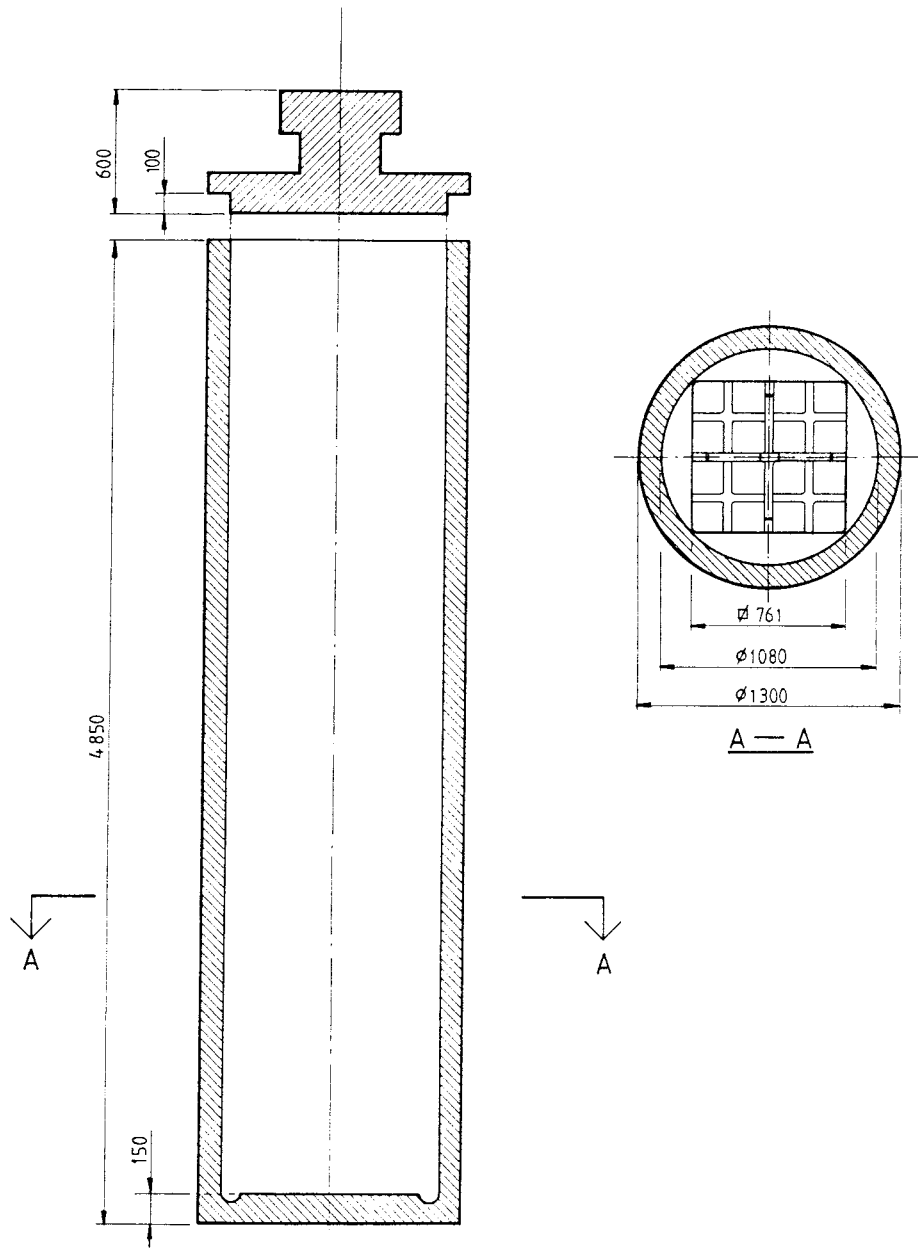

Figure 7-1. Suggested canister design for WPC.

7.4.1 Aerobic period

The walls of the channels and shafts are assumed to be covered with steel liners (10 mm thick), giving a steel surface area of $1.4 \cdot 10^5 \text{ m}^2$ (including both sides of the liners) which is available for corrosion. The total surface area of the canisters is $7 \cdot 10^3 \text{ m}^2$.

Filling the repository with ground rock material and water is expected to be a relatively rapid process with a duration of less than one year. The condition which is least beneficial to the corrosion of the canisters is if the steel liners are passivated. This would minimize the rate of oxygen consumption and prolong

the period during which pitting corrosion will be possible /Marsh et al., 1987/. The rate of corrosion of passive steel at temperatures in the order of 80—100°C is expected to be in the order of 1 μm per year /Marsh, 1985, (Part 2)/. This is equivalent to an oxygen consumption of 300 kg per year. Therefore, with a total oxygen level of 180 kg after the repository has been flooded, anaerobic conditions will be achieved in less than one year.

Assuming that localized corrosion occurs during this period the maximum depth of penetration can be estimated from the expression /Marsh et al., 1986/:

$$P = 8.35 \cdot t^{0.46}$$

where P is pit depth in mm and t is time in years. This predicts a maximum corrosion penetration of 12 mm assuming one year to flood the repository and one year of aerobic conditions in the flooded repository. The above given relationship between maximum pit depth and time is based on pitting kinetic studies in granitic ground water (pH 9.4) at 90°C.

If the corrosion rate of passive steel is a factor of ten lower, i.e. 0.1 μm per year, anaerobic conditions will not be achieved until after about 7 years. The corresponding maximum pit depth will then be about 20 mm.

7.4.2 Anaerobic Period

When the oxygen is removed by corrosion, corrosion of the canisters and the repository liners will continue by direct reaction with water involving hydrogen generation. Experimental studies /Marsh, 1985, (Part 2)/ indicate that these reactions are generally slow (1—10 μm per year), because of the slow kinetics of the cathodic hydrogen evolution reaction and also because the $\text{Fe}(\text{OH})_2$ or Fe_3O_4 corrosion products form a partially protective layer. However, current knowledge cannot prove that these rate limiting factors will remain operative over long periods. Therefore, in estimating the corrosion allowance for the anaerobic period the metal corrosion rates have been used. These rates are 75, 44, and 6.6 μm per year at 90, 50, and 25°C, respectively /Marsh, 1985, (Part 2)/. An extrapolation from these data to 150°C indicates a rate of about 150 μm per year.

The analysis above is made under the assumption that radiolytic production of oxidants outside the canisters can be neglected or at least not be high enough to maintain the passivity of canisters and steel liners. The reason is that the canister wall thickness is 110 mm and that the fuel is 140 years old when the repository is flooded.

7.5 CANISTER LIFE TIME

Of the total 110 mm canister wall thickness, 60 mm is considered as corrosion allowance. The remaining 50 mm will guarantee structural integrity until the deepest pit has penetrated to a depth of 60 mm. A canister will then have a service life of at least 200 years under the unfavourable assumptions that aerobic conditions will prevail for 10 years and under anaerobic conditions, corrosion will proceed at a bare metal rate of 150 μm per year. For a more realistic corrosion rate of 10 to 20 μm per year, the canister service life will be in the range of 1 000 years as long as the corrosion in the welding seams do not set the limit.

7.6 HYDROGEN PRODUCTION

During the anaerobic period, the corrosion will proceed under hydrogen evolution. Assuming the higher corrosion rate of 150 μm per year, and corrosion of both canisters and liners, this would result in a hydrogen production rate of about 4 000 kmol per year, or 90 000 m^3 (at STP) per year. After about 30 years of anaerobic corrosion the 10 mm thick liners are consumed, and the hydrogen production is determined by the corrosion of the canisters only. The production rate will be approximately 200 kmol per year, or 4 400 m^3 (at STP) per year. This situation will prevail another 700 years, until the canisters are totally corroded and the hydrogen evolution due to corrosion is stopped.

With a corrosion rate of 10—20 μm per year, which appears to be more realistic, the hydrogen production rates will be about 10 times lower than the values given above, and the time periods during which the different rates occur will be about 10 times longer. During an initial period of 300 years, approximately 9 000 m^3 of hydrogen is produced each year, and after that, about 440 m^3 per year is produced during the next period of 7 000 years.

7.7 CONCLUSIONS

The life time of the canister is estimated to be in the range of 1000 years with respect to corrosion of the canister walls. In this study, however, it is conservatively assumed that the corrosion of the welding seams limits the life time to 200 years.

The corrosion under anaerobic conditions has been assumed to produce hydrogen gas within a range of 400—90 000 Nm^3 per year. The most realistic assumption is considered to be a rate of about 9 000 Nm^3 per year during a couple of hundred years and thereafter a rate of about 400 Nm^3 per year during several thousand years.

8 FUEL DISSOLUTION

In this chapter the mechanisms and rate of fuel dissolution are discussed. The model used in the safety analysis is presented.

8.1 RELEASE OF RADIONUCLIDES FROM METALLIC COMPONENT

Very little data on radionuclide release from spent fuel cladding and other metallic components are available. C-14 is formed as an activation product from nitrogen impurities and from O-17 in the fuel, in the cladding, and in the reactor primary cooling water. Wilson and Oversby /1985/ reported C-14 results from specimens of bare fuel and fuel specimens in intact or defect cladding. The results do not correlate with test specimen type, suggesting that the measured C-14 was primarily released from the cladding exterior. In the model it has been assumed that 10% of the inventory of C-14 is immediately released when water comes in contact with the fuel. The release of the remaining amount is determined by the fuel oxidation rate.

Nickel present in the repository originates from the inconel alloy. The dissolution of nickel is then determined by the corrosion rate of the alloy. Based on an approximation of the corrosion rate the time to dissolve the total inventory of nickel was estimated to 500 years.

8.2 GAP AND GRAIN BOUNDARY RELEASE

In-reactor irradiation conditions have a significant effect on volatile fission product release, fuel microstructure, and fission product segregation from UO₂ grains. In particular, cesium and iodine released from the fuel matrix to the void space within a fuel element are leached rapidly from the fuel during initial exposure to water. Although no systematic study has been performed for LWR fuel there is a similarity between Cs-137 leachability and fission gas release during irradiation.

Preferential release of fission products from spent fuel appears to be limited to species incompatible with the UO₂ lattice. There is no evidence of preferential leaching of compatible elements, for example, lanthanides and actinides, from spent fuel.

The fission gas release during operation is generally below 1% for LWR fuel. The release of Cs and I is considered as comparable to the fission gas release. However, a fraction of the fuel may have had a higher fission gas release than normal. Therefore, 10% of the inventory of Cs and I has, conservatively, been assumed to be released from the fuel immediately, while the remaining amounts of these nuclides are determined by the fuel oxidation rate.

8.3 UO₂ MATRIX DISSOLUTION

Fission products and actinides inside the UO₂ grains can only be released to the ground water by either of two mechanisms. The first is dissolution of the waste form. If UO₂ is the thermodynamically stable uranium solid in the ground water in a repository, release of the trapped radionuclides will be limited by the amount of UO₂ that dissolves. Even if UO₂ is oxidized to U₄O₉ or U₃O₇ the release will still be limited by the dissolution of the particular uranium oxide, because the oxidation of UO₂ to this extent does not physically disrupt the lattice of the waste form.

The second mode of release could result if UO₂ (or U(IV)) is not a thermodynamically stable solid but it oxidizes to form more oxygen-rich uranium oxide, e.g., U₃O₈ or UO₃ or other U(VI) solids. In these cases radionuclides trapped within the UO₂ grains might be released even if the total concentration of uranium in solution remains very low.

Uranium dioxide is the predominant stable uranium phase under reducing conditions. If the initial solid in spent fuel is UO₂ (or one of the higher oxides U₄O₉ or U₃O₇), it is likely to be stable in ground water under mildly reducing conditions. In reducing ground water the neutral aqueous uranium(IV)hydroxide, U(OH)₄ (aq), is the major solution species over most of the pH range. In oxidizing ground water carbonate-complexes predominate under neutral and moderately basic conditions.

At the time for canister failure, the γ -field in the WPC will have decayed to negligible levels and will have no influence on the redox condition within the WPC. Thus, outside the canisters reducing conditions will be maintained because of the iron and/or magnetite present in the cave.

Inside the canisters the situation will be more complex due to the α -radiolysis of the intruding water. Christensen and Bjergbakke /1987/ have shown that if Fe²⁺ is readily accessible, radiolysis will produce H₂ and Fe(III) thus maintaining a reducing environment also inside the canisters. Under these circumstances the spent fuel will be stable and the release of matrix bound radionuclides will be extremely low. However, α -radiolysis only affects a very thin water layer close to the UO₂ surface and the oxidants produced may react with UO₂ before encountering Fe²⁺ ions.

Very little is known about radiolysis in heterogeneous systems. Here it is assumed that the rates of the reactions involving the solid uranium phase are slower than the reaction rates in a homogeneous system containing Fe²⁺. The calculations performed by Christensen and Bjergbakke /1987/ showed that if the oxidation of UO₂ would be as effective as the oxidation of Fe²⁺, the normalized oxidation rate at the time of canister failure, 340 years after discharge from reactor, would be about $3 \cdot 10^{-4} \text{ a}^{-1}$ ($8 \cdot 10^{-7} \text{ d}^{-1}$) /Skagius et al., 1988/. This rate is in fact higher than what is observed in spent fuel corrosion tests with 15 year old fuel under oxidizing conditions, if the strontium release is assumed to be a monitor of the fuel oxidation/alteration rate. Further, there are indications that strontium may be preferentially leached from crack and grain boundaries. Thus, it is in itself conservative to use strontium as a monitor for the fuel matrix oxidation.

At prolonged leach tests, the strontium release rate has been found to be about $3 \cdot 10^{-7} \text{ d}^{-1}$ under oxidizing conditions /Forsyth et al., 1986/. Under reducing conditions only shorter exposures have been performed and the strontium release rates are found to be about $1 \cdot 10^{-7} \text{ d}^{-1}$. This value is 10 to 30 times lower than the corresponding release rate under oxidizing conditions. Furthermore, no differences in strontium release attributable to α -radiolysis has been found between high burnup fuel with an α -dose rate of about $25 \text{ rad} \cdot \text{s}^{-1}$ and low burnup

fuel with an α -dose rate of about $0.04 \text{ rad} \cdot \text{s}^{-1}$ /Forsyth et al., 1986/. The expected dose rate for the fuel in the WPC is about $15 \text{ rad} \cdot \text{s}^{-1}$.

Therefore, in view of the experimental evidence, the calculated initial fuel oxidation rate of about $3 \cdot 10^{-4} \text{ a}^{-1}$ ($8 \cdot 10^{-7} \text{ d}^{-1}$) seems unrealistic. Available experimental data clearly point at a value most probably at least ten times lower. However, lacking more detailed data on α -radiolytic oxidation of UO_2 as well as on the possible effects of elevated temperatures, a five times lower initial fuel oxidation rate, i.e. about $6 \cdot 10^{-5} \text{ a}^{-1}$, has conservatively been assumed.

8.4 CONCLUSIONS

The model describing the nuclide release from the fuel and metallic components to the ground water penetrating the canisters can be summarized as follows:

- The oxidants produced by the α -radiolysis react with the fuel and oxidize uranium to the hexavalent state. This process also liberates the radionuclides incorporated in the fuel matrix. Since uranium and some of the other nuclides are much more soluble in the higher oxidation state it is conservatively assumed that nuclides are dissolved with a rate determined by the radiolytic oxidation of the fuel or by the solubility of the nuclide under oxidizing conditions. The radiolytic fuel oxidation rate at the time for canister breakthrough is assumed to be $6.5 \cdot 10^{-5} \text{ a}^{-1}$, leading to an oxidation time of $1.2 \cdot 10^6$ years for the 1 000 tonnes of fuel stored in one WPC;
- I, Cs, and C might to some extent be localized to the surface of the fuel pellets. It is therefore assumed that 10% of the inventory of these nuclides is immediately dissolved while the remaining amount is determined by the fuel oxidation rate;
- Ni present in the storage originates from the inconel alloy. Based on an estimate of the corrosion rate of the alloy, a dissolution time of 500 years for the total inventory of Ni is assumed;
- This model differs from the one used in the KBS-3 study /KBS-3, 1983/, which is based on the solubility of uranium carbonate complexes. In the KBS-3 study the radiolysis was calculated to have decreased to an insignificant level at the time of water breakthrough into the copper canisters.

9 RADIONUCLIDE TRANSPORT IN NEAR FIELD

The conceptual model for radionuclide migration in the near field, applied in the safety analysis, is described in this chapter. The conclusions from the performed studies of expected events, presented in the previous chapters, have formed the basis for the scenario selected for the safety analysis. The interface between the near field and far field is here defined as being located in the rock mass just outside the bentonite/sand barrier.

9.1 MIGRATION TO OUTSIDE OF CANISTER

Corrosion breakthrough in all canisters in the repository is assumed to occur 200 years after repository closure. The fuel pellets in the canisters are surrounded by a zircaloy pipe, but in the safety analysis it has conservatively been assumed that water comes in contact with the fuel pellets as soon as it has penetrated through the canister (Chapter 7).

In contact with the water the fuel starts to dissolve. The nuclide dissolution rate is determined by the radiolytic fuel oxidation rate or the solubility of the nuclide under oxidizing conditions (Chapter 8).

The anaerobic corrosion of canisters and liners generates divalent iron corrosion products. It is therefore assumed that reducing conditions prevail everywhere from the corroded canister walls to the rock outside the bentonite/sand barrier even after all the iron material has corroded away.

The dissolved radionuclides escape through the corroded canister and enter the ground rock outside the canisters. Before entering the ground rock the uranium and other redox sensitive compounds, e.g., actinides and technetium, can react with the ferrous corrosion products. This will result in a precipitation of the redox sensitive compounds that have a lower solubility in the lower oxidation state.

The corroded canister might also constitute a barrier to the nuclide transport since the corrosion products have a certain sorption capacity and the expansion of the corrosion products might limit the porosity of the corroded canister walls. There is at present, however, no reliable way to quantitatively estimate these effects. Therefore, the resistance to transport, that the corroded canisters might provide, has not been accounted for.

The anaerobic corrosion of iron metal will generate hydrogen gas. With the expected hydrogen production rate it is very likely that hydrogen bubbles will be formed. A hydrogen gas phase in the pores between the corrosion products will expel the water and thereby limit the transport of radionuclides from the canister. Due to capillary forces it is, however, not enough to totally prevent water from entering the canister. It is always possible to imagine a situation where water enters through small pores with gas escaping simultaneous through large pores. A reliable estimate of the hydrogen production rate and its quantitative impact on the transport of radionuclides to the outside of the canister is, however, difficult to make. Therefore, no barrier effect has been considered due to hydrogen gas bubble formation.

9.2 MIGRATION THROUGH SAND BACK-FILL AND INNER ROCK MASS

The source term for the nuclide migration from the canister surface is the concentration of the nuclide in the ground water just outside the canister surface. The concentration at this location can not exceed the solubility of the nuclide under reducing conditions, which prevail everywhere outside the canister surface. The nuclide transport from the canisters is assumed to be by radial diffusion through the canister channels refilled with finely ground rock material to a fissure opening in the rock between the canister channels (Figure 9-1). This assumption has been made since it has been concluded that the excavation of the slot for the bentonite/sand barrier probably will open existing fracture structures in the rock mass between the storage space and the bentonite/sand barrier, both horizontally and vertically, with an increased hydraulic conductivity as a result, see Chapter 6. This in combination with the high resistance to water flow in the finely ground rock material in the canister channels will probably short-circuit the thermo-induced water circulation in the channels and shafts, i.e. the water circulation will occur in the fractures in the rock while the water in the channels and shafts remains stagnant. The axial diffusion in the canister channels directed towards the inner and outer ventilation shafts are neglected since the cross-sectional area available for diffusion in the axial direction is small compared to the area for diffusion in the radial direction.

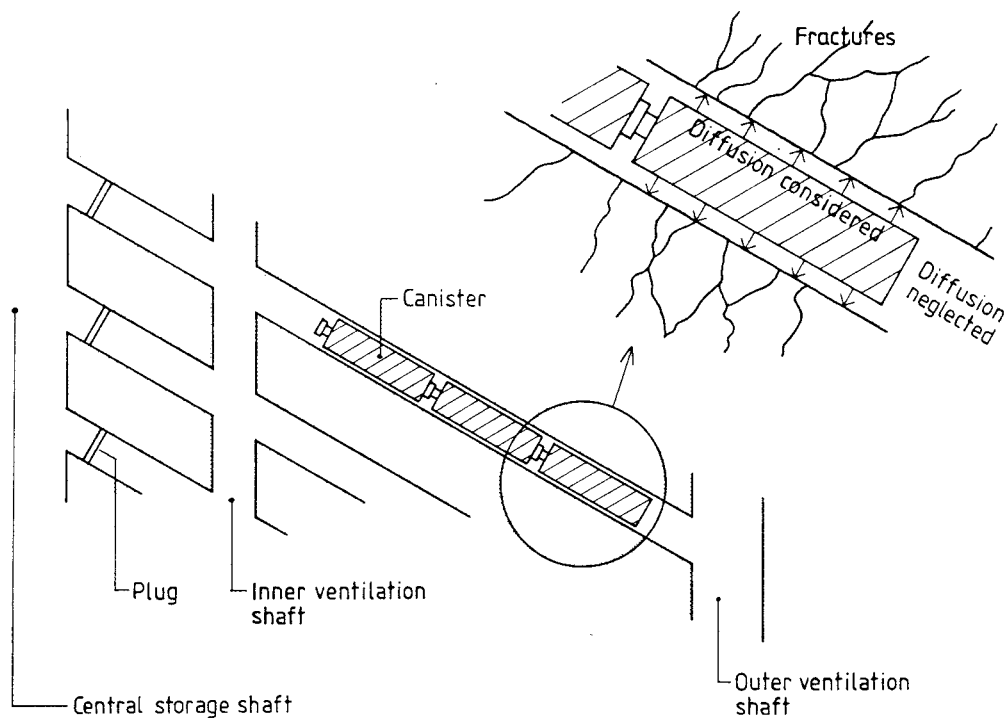

Figure 9-1. Schematic illustration of the transport from the corroded canister to the fissures in the rock surrounding the canister channel.

Some nuclides with low solubility, for example Pu, can be released in colloid or particle form from the fuel to the water. Here it is, however, assumed that such particles and colloids have difficulties in escaping through the finely ground back-fill (0.1 mm) in the canister channels. Colloid and particle transport has therefore not been considered.

The flowing water in the fissures in the rock outside the channels and shafts will transport the nuclides to the inside of the bentonite/sand barrier. During the transport, the nuclides will be sorbed to the fracture surfaces and diffuse into the open connected micropore system of the bulk rock. At present, not enough is known about the fracture surface available for sorption.

Conservative estimates of this surface together with the expected high hydraulic conductivity will render the resistance to radionuclide transport in the water conducting fractures of the inner rock mass small as compared to the transport resistance in the bentonite/sand barrier and the back-filled finely ground rock material. The effects of weathering processes and possible redistribution of silica and calcite due to the temperature gradient are also difficult to quantify.

The inner rock mass has therefore not been included in the transport calculations. Consequently, the radionuclides are assumed to enter the bentonite/sand barrier immediately after leaving the canister channels.

The hydrogen gas from the corrosion of canisters and liners is assumed to escape through the top of the cave without affecting the nuclide migration.

9.3 MIGRATION THROUGH THE BENTONITE/SAND BARRIER

The nuclide transport through the bentonite/sand barrier will occur by advection and diffusion. The heat generated by the fuel will influence the water flow in the rock outside the bentonite/sand barrier in such a way that inflow of water will occur through the bottom of the bentonite/sand barrier and outflow through the top. The magnitude of the thermo-induced water flow through the barrier is dependent on the assumed hydraulic conductivities in the bentonite/sand barrier and in the internal rock mass, see Chapter 9. These hydraulic conductivities will also determine whether ground water flow driven by the natural gradient or by diffusion will be the governing transport mechanism in the bentonite/sand barrier at longer times when the temperature gradient has decayed.

With a hydraulic conductivity of $10^{-11} \text{ m} \cdot \text{s}^{-1}$ in the top part and $10^{-10} \text{ m} \cdot \text{s}^{-1}$ in the bottom part of the bentonite/sand barrier and $10^{-9} \text{ m} \cdot \text{s}^{-1}$ in the inner rock mass the bentonite/sand will act as a diffusion barrier except during the first 5 000 years after canister breakthrough when transport out through the top of the barrier by the thermo-induced flow will contribute. In this case, further referred to as the Low Flow Through Case the nuclide transport through the top of the barrier and subsequent release to the ground water passing the barrier outside is assumed to occur by diffusion and thermo-induced flow acting in parallel. Because of the decrease in thermal power in the fuel the thermo-induced flow through the top is decreasing with time resulting in diffusion dominated release from the outer boundary of the top of the barrier at longer times. The nuclide transport through the cylindrical part of the barrier and subsequent release to the water flowing outside the barrier is assumed to be by diffusion only.

The thermo-induced flow passing along the outside of the bentonite/sand barrier is also decreasing with time. The maximum flow rate is approximately as high as the natural gradient caused flow rate that in average has been found in

Swedish rock in site investigations at 200 meters depth. It has therefore been assumed that the natural gradient determines the magnitude and direction of the water flow outside the bentonite/sand barrier during all times after canister breakthrough.

It is not proven that a hydraulic conductivity of $10^{-11} \text{ m} \cdot \text{s}^{-1}$ on the average can be achieved in the top part of the barrier. Furthermore the measure due to hydrogen gas problem is to use a low graded bentonite mixture with a higher hydraulic conductivity. A 10 times higher value than in the Low Flow Through Case is possible. The hydraulic conductivity in the inner rock mass will most probably also be higher than that assumed in the Low Flow Through Case because of the large fracture apertures expected in that part of the rock, see Chapter 6, and the higher conductivity in the back-fill material in the channels and shafts. With a hydraulic conductivity of $10^{-10} \text{ m} \cdot \text{s}^{-1}$ in the bentonite/sand barrier and $10^{-7} \text{ m} \cdot \text{s}^{-1}$ in the inner rock mass, the thermo-induced flow through the top of the bentonite/sand barrier will be approximately 20 times higher than in the Low Flow Through Case. Another effect of these higher conductivities will be an increase in the natural gradient caused water flow through the barrier. Neglecting the decrease of the natural gradient over the barrier due to the presence of the hydraulic cage will result in a nuclide release from the barrier that also at longer times is determined by advection and not by diffusion. This scenario is further referred to as the High Flow Through Case.

9.4 CONCLUSIONS

The conceptual model for the near field migration, on which the calculations in the safety analysis are based, can be summarized as follows:

- Water breakthrough occurs in all canisters after 200 years of water contact, i.e. 340 years after fuel discharge from reactor;
- The corroded canisters provide no resistance to transport;
- The source term for the nuclide migration from the canister surface is the nuclide release rate from the fuel. The concentration at the canister-back-fill interface is, however, limited by the solubility of the nuclide under reducing conditions;
- Reducing conditions are maintained inside the repository;
- The nuclide transport through the back-filled finely ground rock in the canister channels occurs by radial diffusion;
- The resistance to nuclide transport in the rock between the storage space and the bentonite/sand barrier is neglected;
- The nuclide transport through the top of the bentonite/sand barrier occurs by advection and diffusion acting in parallel. In the Low Flow Through Case the advective transport is caused by the thermal gradient in the repository. In the High Flow Through Case the advective transport is caused by the sum of the thermally induced and natural gradient induced flow;
- The nuclide transport through the remaining part of the bentonite/sand barrier is dominated by diffusion;
- The nuclides are released from the bentonite / sand barrier (from the near field) by the water flowing through the barrier and by diffusion to the slowly moving water in the rock immediately outside the barrier.

10 THERMALLY INDUCED GROUND WATER FLOW

This chapter presents the results of the analysis on the ground water movements caused by the thermal load. Calculations have been conducted for the bentonite/sand barrier alone, for the barrier and the hydraulic cage in combination and finally for both these cases including a high-conductive zone in the bottom region of the WPC.

10.1 GENERAL

The heat generated by the spent fuel will affect the ground water movements around and through the bentonite/sand barrier. The flow induced by the thermal load will be directed upwards and the flow rate will be almost proportional to the prevailing temperature.

10.2 CALCULATION MODELS

The flow rate through and in the vicinity of the cave has been analyzed in two phases /Hopkirk, 1988/.

The first phase comprised a simplified model of the part inside the bentonite/sand barrier. The thermal load was considered to be evenly distributed in the whole rock mass and the hydraulic properties of the rock mass was set to be the same as for the rock mass outside the barrier. The barrier was modelled as a cylinder. The ground water environment was assumed to be stagnant, thus with no transversal flow. Fluid was set to locally be at the same temperature as the solid material. The values from this calculation were utilized in the Low Flow Through Case in Chapter 15 for estimation of the nuclide release to the water flowing outside the bentonite/sand barrier.

In the second phase the interior part was modelled in more detail giving distinct positions of the thermal load as well as accurate hydraulic properties to the back-filled openings and the rock mass inside the bentonite/sand barrier. Still, however, a rough model for temperature distribution was chosen, which overestimates the temperature for a specified thermal load. This discrepancy is overcome by using such a low thermal load that the correct temperature field is achieved. Other parts of the model was copied from the first calculations. In neither of the two phases consideration is taken to the decreased hydraulic conductivity in the rock mass just outside the bentonite/sand barrier caused by the heat expansion of the rock mass.

The results of the second phase calculations, when compared with the results from the first phase calculations, are a higher Darcy's velocity out through the top of the bentonite/sand barrier but about the same velocity along the cylindrical parts of the barrier with components of downward flows imposing the development of buoyancy cells. The values from this second phase calculation were utilized in the analysis of the High Flow Through Case.

10.3 NUMERICAL RESULTS FROM CALCULATIONS

In Table 10-1 the parameters used in the different calculation exercises are presented. The outcome in terms of Darcy's velocity and total flow out through the top of the bentonite/sand barrier is presented for major cases in Table 10-2.

Case A represents the simpler model and Cases 6 and 7 the more detailed one. Cases A and 6 consider the bentonite/sand barrier alone, while Case 7 includes the hydraulic cage.

The factors changing the flow pattern and increasing the flow from Case A to Case 6 are the increase in hydraulic conductivity in the interior parts and in the top part of the bentonite/sand barrier. A two orders of magnitude difference in hydraulic conductivity between the inside and the outside directs a major part of the water flow to pass through the inside of the "cylinder", as is visualized in Figure 10-1. In Case A the inner rock mass represents a noticeable resistance against flow, while the 100 times increase in hydraulic conductivity leads to a negligible resistance in that rock mass.

Table 10-1. Parameters used in different computer runs with major influences on the difference in results.

Case A	First model with simpler description of rock mass inside bentonite/sand barrier.		
Case 6	More detailed model concerning interior parts. Thermal load decreased in order to adapt to the maximum design temperature of 150°C.		
Case 7	Same as Case 6 with the addition of the hydraulic cage.		
	Thermal load and resulting peak temperature	Hydraulic conductivity in bentonite/sand barrier $\text{m} \cdot \text{s}^{-1}$	Hydraulic properties inside bentonite/sand barrier $\text{m} \cdot \text{s}^{-1}$
Case A	1.13 MW, 280°C	Upper cone: 10^{-11} Vert. part: 10^{-10} Bottom cone: 10^{-10}	As in rock outside barrier (10^{-9})
Case 6—7	0.6 MW, 160°C	10^{-10}	Back-fill: 10^{-5} . Rock inside: 10^{-7}

Table 10-2. Results of computer runs. Maximum values are presented.

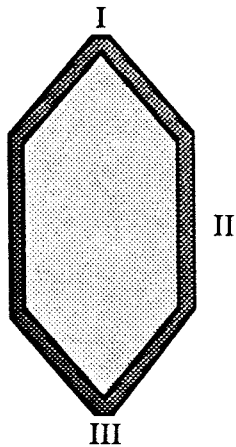

Measuring points

Darcy's velocity in measuring points, $m \cdot a^{-1}$. Negative velocity denotes downward for **vertical** and inwards repository for **horizontal** direction. **Resultant** is not denoted with direction.

		I	II	III	Time Year
Case A	Vertical	3.4 E-4	3.6 E-4	1.7 E-4	394
	Horizontal	7.9 E-6	1.9 E-5	-7.3 E-6	"
	(Resultant	3.4 E-4	3.6 E-4	1.7 E-4)	
Case 6	Vertical	5.3 E-3	-8.0 E-5	5.3 E-3	544
	Horizontal	6.3 E-4	9.6 E-5	-4.2 E-5	"
	(Resultant	5.3 E-3	-1.2 E-4	5.3 E-3)	
Case 7	Vertical	5.5 E-3	2.1 E-5	5.5 E-3	544
	Horizontal	5.9 E-4	1.2 E-4	-4.1 E-5	"
	(Resultant	5.5 E-3	1.2 E-4	5.5 E-3)	

Maximum thermally induced flow through top of bentonite/sand barrier, $m^3 \cdot a^{-1}$.

Case A	4
Case 6	70

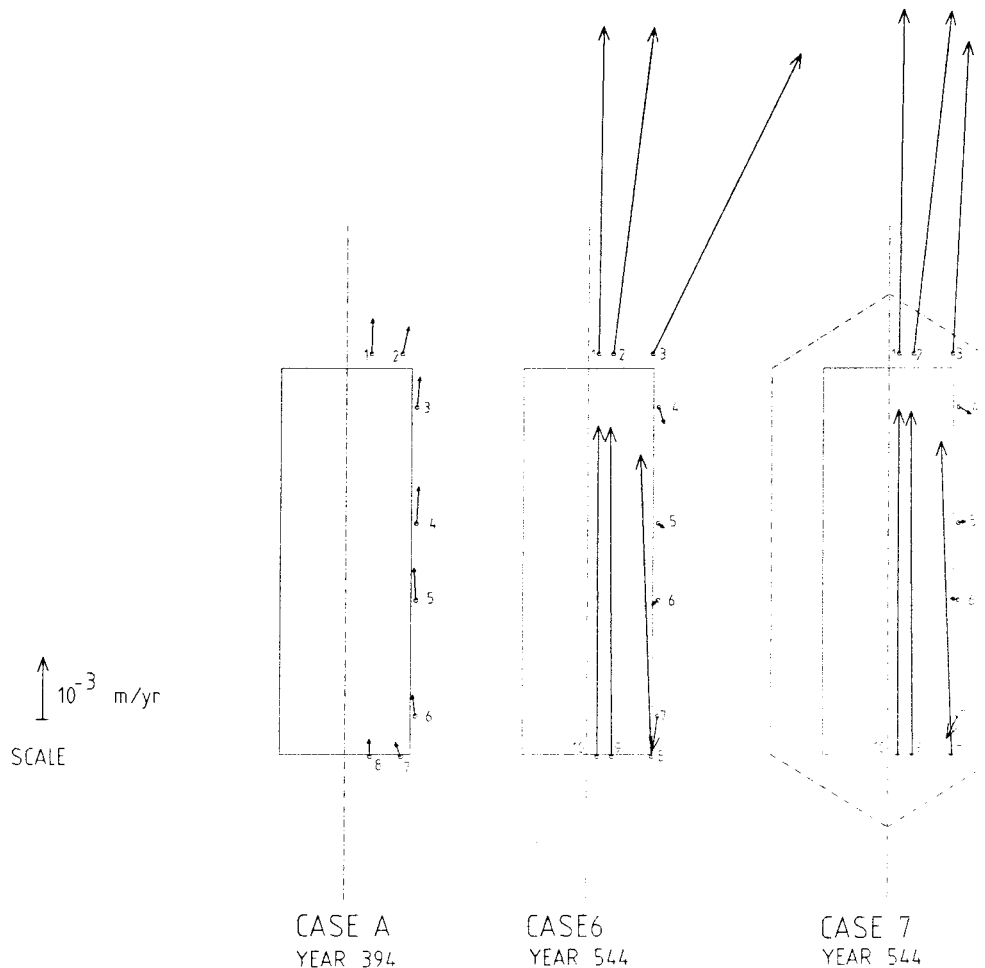

Figure 10-1. Thermally induced flow for Cases A, 6, and 7. Arrows show Darcy's velocity.

Outside the "cylinder" a homogeneous flow upwards is shown for Case A, while buoyancy cells tend to develop giving a complex picture of the true water flow close to the barrier in Case 6.

The peak resultant flow in points A and C, see Table 10-2, has increased with about 15 and 30 times, respectively, from Case A to Case 6. This means that in Case A the flow is about the same as the assumed natural ground water flow at 200 m depth. In Case 6 the flow through the bentonite/sand barrier then is 15 times higher.

The values of Darcy's velocity decrease by about 4 to 5 times during the first three thousand years.

The influence of a hydraulic cage in the structure is of no significant importance. The velocities through or along the bentonite/sand barrier change only slightly when the cage is present.

The size and direction of Darcy's velocity at the cylindrical part of the barrier seem to be difficult to determine with accuracy. Further analysis is required for this task. Analysis is also required for the determination of how water moves in the direction upwards along the barrier including the number of turnovers of

fresh water. Several turnovers will affect the “diffusion resistance” described in Section 5.4.

10.4 CONCLUSIONS

In the calculations two alternatives are defined as follows:

- High Flow Through Case, which is Case 6 presented above;
- Low Flow Through Case, which is Case A presented above.

11 GROUND WATER TRANSPORT IN BEDROCK

The basis for the channel flow theory is outlined and the background data used in the calculations are presented.

11.1 GENERAL

One conservative interpretation of the results from observations of water flow in tunnels and drifts in fractured Swedish bedrock is that the water flow is concentrated to only some transportation paths (channels) out of the many available /Moreno et al., 1988/. The channels are characterized by a certain width and a certain flow rate. Different channels have different flow rates and the variation in flow rate is considerable.

11.2 OBSERVATIONS IN SFR AT FORSMARK

During construction of the SFR repository for low- and intermediate level waste, a detailed collection of data on water flow into tunnels and drifts was made. The totally observed area in tunnels and drifts was 14 000 m². At 164 different spots in the ceiling a total inflow of about 30 l·min⁻¹ was registered.

A compilation of all measured data from each individual spot is shown in Table 11-1. Six ranges of flow rates were set up and each of the measured spots were listed in one of the ranges according to measured flow rates.

Table 11-1. Flow rates in different flow rate ranges in 14 000 m² of ceiling area in tunnels and drifts in SFR-Forsmark.

Flow rate range l·min ⁻¹	Number of Spots	Flow rate l·min ⁻¹	Cumulative % flow rate
<0.1	67	2.5	8.3
0.1—0.2	38	3.8	20.9
0.2—0.4	41	9.3	51.4
0.4—0.8	12	6.3	72.1
0.8—1.6	4	4.5	86.9
>1.6	2	4.0	100.0
TOTAL	164	30.5	

The result of the SFR measurements is that there is only one channel per 85 m² of ceiling area at that site. Of the observed channels only a few carry the major proportion of the water. About 50% of the water flow takes place in less than 10% of the channels. The wetted surface of the channels per volume of rock is then very small, if only those channels which were observed to carry most of the water are accounted for in a nuclide transportation model.

11.3 OBSERVATIONS IN KYMMEN TUNNEL

The Kymmen tunnel is a full-face bored tunnel with a diameter of 4.6 m. It has a length of 4 500 m and passes through four major rock types: gneiss-granite (type A), gneiss-granite with slabs of amphibolite (type B), fine grained leptite (type C), and amphibolite (type D).

As in SFR, ranges of flow rates have been defined and the observed inflow at each spot grouped according to mean values. A compilation of the result is presented in Table 11-2. In the Kymmen tunnel the frequency of leakage spots is one spot per 163 m² of tunnel ceiling.

Table 11-2. Number of spots in different flow rate ranges in 4 500 m of Kymmen tunnel.

Flow rate range l min ⁻¹	TYPE OF ROCK			
	A	B	C	D
0.01—0.2	11	68	163	—
0.2 — 1.5	5	34	95	2
1.5 — 6.5	—	4	4	—
>6.5	—	—	4	—

- Rock type A: Gneiss-granite
- B: Gneiss-granite with slabs of amphibolite
- C: Fine-grained leptite
- D: Amphibolite

11.4 OBSERVATIONS IN STRIPA MINE

In the Stripa 3D experiment a 75 m long drift was excavated on the 360 m level. The drift was covered with 375 individual plastic sheets (2 m²). The flow rate from each sheet was monitored for nearly three years. The result of the measurements is shown in Table 11-3. This table shows that about 50% of the flow takes place in only about 3% of the observed area. It was further found that the flow rate varied considerably between different areas and between different sheets in the different areas. There was a concentration of flow to some areas whereas other areas were dry or had very small flow rates.

Table 11-3. Flow rates in different flow rate ranges in 75 m of drift in Stripa mine.

Flow rate range ml · h ⁻¹	Number of sheets	Flow rate total ml · h ⁻¹	Cumulative % flow rate
< 0.1	266	0	0
0.1— 0.2	13	1.3	0.2
0.2— 0.4	7	1.6	0.4
0.4— 0.8	10	5.6	1.3
0.8— 1.6	20	22.6	4.8
1.6— 3.2	19	46.1	11.9
3.2— 6.4	14	63.0	21.7
6.4—12.8	12	108.5	38.4
12.8—25.6	7	124.0	57.5
25.6—51.2	6	215.0	90.7
51.2	1	60.0	100.0
Total	375	674.7	

11.5 CONCEPTUAL MODEL FOR FLOW IN CHANNELS

From the observations it was concluded that the water flow takes place in a few channels only. These channels are seldom wider than a few meters and are often much more narrow. The sorption surface is reduced considerably in comparison with the case where all fractures are open to water flow. Observed fractures in the Swedish bedrock have in average a spacing from tens of centimeters to a few meters. This gives a fractured trace length per m² of rock surface in the range of 0.5 — 5 m · m⁻².

The observations resulted in that 90% of the flow rate takes place in one channel per 20 m² in Stripa, one channel per 85 m² in SFR, and one channel per 163 m² in the Kymmen tunnel. If it is assumed that a channel on the average is one meter wide, the wet fracture length per area would then be 1/163 — 1/20 m². These figures may also be interpreted as average wet fracture spacings of 20 and 163 m, if all fractures were parallel and of infinite extent. This means that there are some orders of magnitude less fracture surface available for nuclide sorption than if all the fractures were open.

For short distances, about 100 m, the different channels are not considered to mix regularly and are looked upon as a bundle of independent channels, each with its own flow rate and wetted surface. The channels with a large flow rate and small sorption surface will carry the nuclides in large amounts, and will be the dominating transport paths.

At longer distances channels will meet and the water in the channels can be expected to mix regularly. It is assumed that the channels will not meet until after a distance which is equal to the average distance between channels. This distance is in the order of the square root of the area of the channel, meaning that for 150 m² the distance is about 12 m. Probably the distance between intersections is larger but also a distance of ten meter will result in negligible effects from mixing within the distance of 100 m. The full effect is seen only when the transport distance is in the range of 500 m in the rock.

11.6 CONCLUSIONS

The water flow in the bedrock is chosen to be described in accordance with the conservative interpretations of observations in Swedish tunnels and drifts, i.e. flow in channels.

No specific site has been considered in the calculations on nuclide releases presented here. The choice made is to extend the flow rate distribution observed in the SFR repository to the rock mass between the WPC repository and the biosphere.

12 PERFORMANCE OF HYDRAULIC CAGE

In this chapter an attempt is made to quantify the effect on the rate of nuclide release when a cage is present. Firstly the situation is discussed when diffusion through the bentonite/sand barrier dominates the nuclide release and secondly when the thermally induced ground water flow dominates.

12.1 GENERAL

In the SKN study /SKN Report 16, Chapter 7, 1985/ the efficiency of the cage was analyzed for the natural ground water gradient with the assumption that the host rock was a homogeneous porous medium. Thus all transportation paths could be intersected. The efficiency was set to be a function of the distance between the drains, which also could vary in diameter. An efficiency of 98% was considered obtainable as it required only a moderate number of drains.

In case of the application of a channeling model for ground water transportation the basis for predicting the absolute value of efficiency changes. This new analysis has not been the concern of this study. Therefore an even figure of 90% efficiency has been adopted in the discussions of the hydraulic cage. The effect on nuclide releases, however, changes dependent on how the structure of channels is. Below, further outlined in /SKB, 1989/, two different cases are assumed.

An illustration of the function of the cage is shown in Figure 12-1.

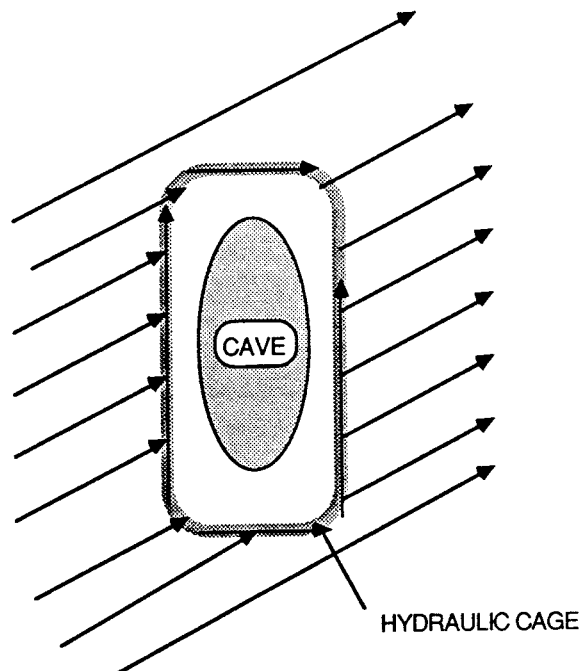

Figure 12-1. Illustration of how the hydraulic cage diverts the natural ground water flow into the cage and past the repository.

12.2 CHANNEL MEDIA APPROACH

The following two cases are discussed:

- Case 1: A fraction of the channels are not intersected by the hydraulic cage.
- Case 2: All the channels are intersected by the cage.

12.2.1 A Fraction of Channels are not Intersected

The channels which are not intersected by the hydraulic cage maintain the same hydraulic pressure difference as that over the cage itself. The water velocity in these channels will not be affected by the cage.

For this case the effect on nuclide releases is proportional to the efficiency of the hydraulic cage. A 90% efficiency, that is 90% of the channels are intersected by the cage, would decrease the radionuclide release by a factor of 10.

12.2.2 All Channels are Intersected

In this case it is assumed that the water which penetrates into the cage spreads out in all existing channels inside the cage. The water velocity decreases evenly in all parts of the rock mass. With a 90% efficiency of the cage the velocity decreases by a factor of 10. This will have two effects.

One is that the release rate of nuclides from the bentonite/sand barrier will decrease by a factor of about 3 due to the square root dependence on the flow rate in the near field.

The other is that the residence time of the water in the channels inside the cage will be a factor of 10 longer than in the case where there is no cage present. The effect will be the same as if the travel distance were to be increased by a factor of 10. The 50 m thick rock between the bentonite/sand barrier and the cage would have the same retardation effect as a 500 m long travel distance outside the cage. This effect is most important to high-sorbing nuclides.

The Case 2 has two alternative subcases:

- Case 2a: The channels pass out through the cage without mixing in the water in the cage.
- Case 2b: The water in the channels mixes fully with the water in the cage.

The difference between these cases is small if the water was to travel in similar pathways. Then the radionuclide retardation would be the same and the effluent rate of the nuclides would be the same. The difference would be that in Case 2a the flow rate of water is 10 times lower than in Case 2b, but the concentration is 10 times higher. There may, however, be a difference in the flow paths in the two cases due to the presence of the cage. This structure is larger than the bentonite/sand barrier and will connect more channels. The chance for intersecting fast channels increases.

12.3 ATTEMPT TO QUANTIFY DIFFERENCE WITH OR WITHOUT CAGE AT NATURAL GRADIENT

12.3.1 Cage Influence on far Field Stream Lines

The hydraulic gradient over the cage will be zero ideally. With the assumption that the flow rate is decreased by a factor of 10, the gradient will be 10 times lower than when no cage is present, assuming that all other parameters are unchanged. This means that the gradient just outside the cage will increase if the boundary conditions far away are unchanged. This is illustrated in Figure 12-2. The flow rate in the cage will be more than two times higher than it would have been in the same rock volume with no cage present. This will shorten the travel time of the water from the cage to surface.

12.3.2 Calculated Release Rates to Biosphere of some Nuclides

In order to quantify the release rates from the repository for the two cases calculations have been conducted for three radionuclides: Pu-239, Pu-242, and U-238 /SKB, 1989/.

Pu-239 has a half life of 24 000 years and a sorption coefficient of $5 \text{ m}^3 \cdot \text{kg}^{-1}$. This radionuclide would significantly decay during a long transport in rock. The half life of Pu-242 is longer and the impact of the transportation distance is expected to be less. U-238 has a very long half life and a sorption coefficient of $1 \text{ m}^3 \cdot \text{kg}^{-1}$ has been assumed. This means that the influence of the transport distance is expected to be negligible.

In Case 1 the source term, i.e. the release rate from the bentonite/sand barrier, is reduced by a factor of 10. The concentration in the channels carrying nuclides is the same as if no cage was present.

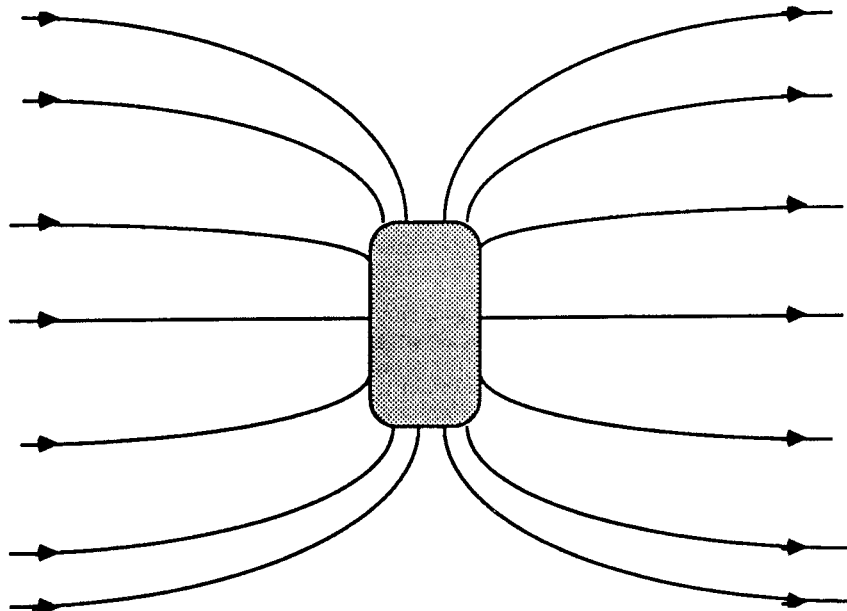

Figure 12-2. Illustration of how stream lines are drawn into the hydraulic cage.

In Case 2 the source term is reduced by a factor of 3. The effective transport distance in the rock outside the hydraulic cage is reduced by a factor of 2 due to the increased ground water flow rate in this region with a cage present.

As expected the result for U-238 is not affected in any significant way by the transportation distance. The results for Pu-239 and Pu-242 are shown in Figures 12-3 and 12-4, respectively. They indicate that for shorter distances, 100-200 m, the positive influence from a functioning hydraulic cage is significant. At longer distances, about 1 000 m, the influence has decreased substantially. In case of Pu-239 it might even be that the release rate is higher with the cage than without.

The results imply that much work will be needed, especially in collecting data on channeling and the understanding of the nature of ground water flow in the rock, in order to be able to accurately quantify the effects of the hydraulic cage.

The maximum release rates are calculated for distances up to about 1 500 m away from the bentonite/sand barrier. They are calculated for a source with a unit release rate. The released nuclides decay according to the half life of each nuclide. For the cases with the cage present two distances between the bentonite/sand barrier and the cage have been considered: 25 and 50 m.

12.4 THERMALLY INDUCED FLOW DOMINATES THE RELEASE RATE

In the High Flow Through Case the nuclide release from the bentonite-sand barrier is dominated by water flowing through the repository. The flow is caused by both the natural gradient and thermal gradient. The thermally induced flow is not influenced by the presence of a hydraulic cage.

In the early time period the release from the bentonite/sand barrier is dominated by the thermal flow. During this time period a cage will then not significantly reduce the release from the barrier.

After about 10 000 years the thermally induced flow has decreased to the same value as the natural ground water flow. At that time a hydraulic cage will reduce the release rates from the bentonite/sand barrier to about half the value obtained without the cage, if the cage will reduce the natural gradient over the repository with a factor of 10. This reduction will not affect the peak release of fission and activation products and only to a minor degree the peak release of actinides.

After about 100 000 years the thermal gradient has decayed and the dominating release from the barrier is occurring by the natural ground water flow through the top of the barrier. A hydraulic cage will then for times longer than 100 000 years reduce the release rates from the barrier with about a factor of 10 in case of a 90% efficiency.

It is not foreseen that the change in travel time in the rock inside the cage, that might occur with a hydraulic cage present, will give an additional effect that is significant. For the High Flow Through Case the reduction in nuclide release rates to the biosphere achieved with a hydraulic cage would then be equal to the estimated reduction in the release rates from the bentonite/sand barrier.

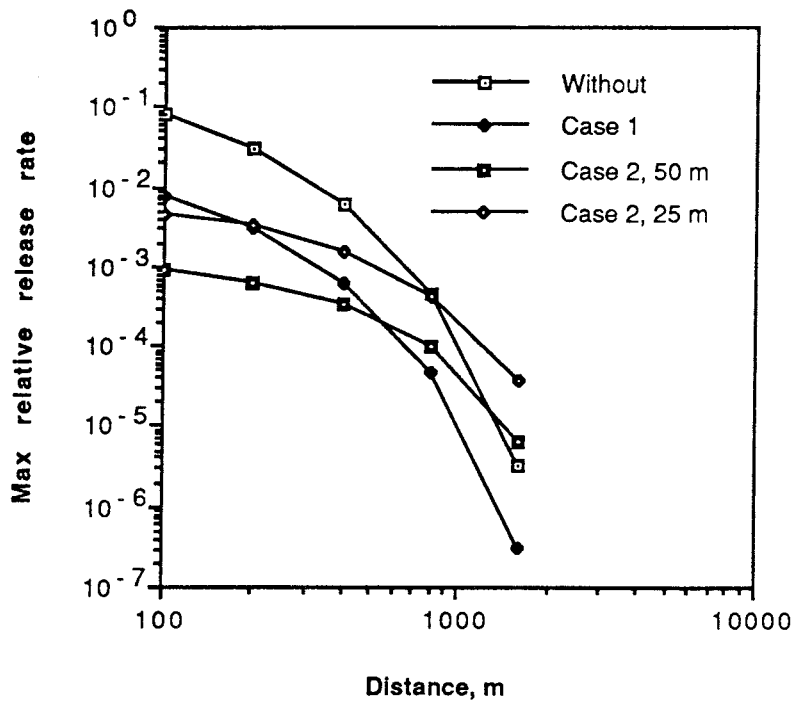

Figure 12-3. Maximum release rates to the biosphere for Pu-239 at different distances from the bentonite/sand barrier.

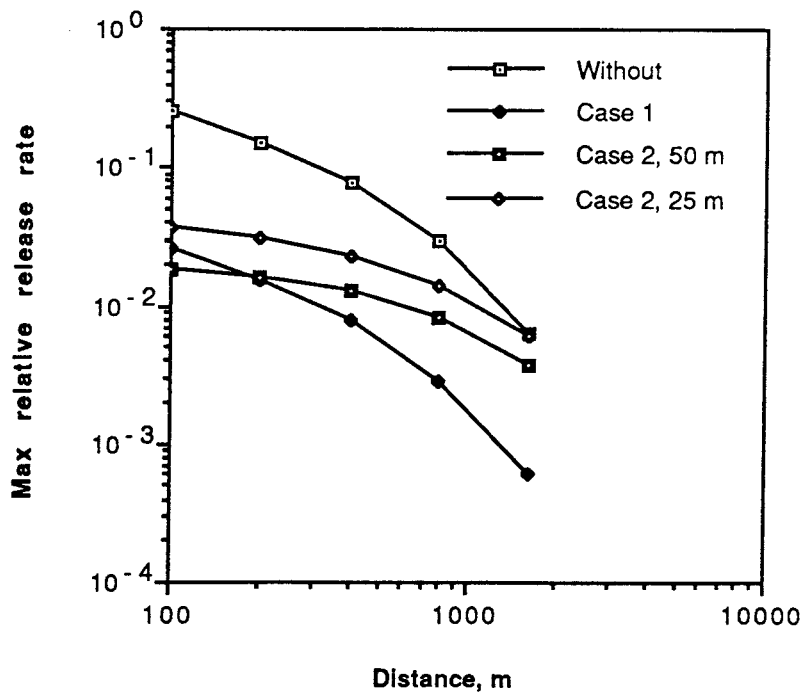

Figure 12-4. Maximum release rates to the biosphere for Pu-242 at different distances from the bentonite/sand barrier.

12.5 CONCLUSIONS

The presence of the hydraulic cage will not influence the ground water flow through the repository, which is caused by the thermal gradient. Only the ground water flow driven by the natural gradient is affected.

Therefore in the High Flow Through Case the effect of the hydraulic cage on the release rate is negligible.

In the Low Flow Through Case the maximum release rate is reduced by the cage. The efficiency is dependent on the hydrology nature of the rock and the rate of water that is attracted by the cage. When assuming that 90% of the water flows in the cage and 10% through it, the efficiency is estimated to correspond to a decrease of the release rate of nuclides by a factor of between 3 and 10.

As the thermally induced flow is found to be of great importance, it is noticed that the demands on the bentonite/sand barrier are high thus making this barrier more important to the total nuclide release rate than the hydraulic cage.

13 DILUTION OF NUCLIDES IN WELL SCENARIOS

This chapter presents the bases for both the optimistic and conservative values of dilution of nuclides released to a well, which are used in the calculations of dose exposure to man.

13.1 GENERAL

During the transport through the bedrock and at the release into the biosphere, the radionuclides are diluted. The degree of dilution is highly dependent on site characterization and repository specific factors:

- Hydraulic characteristics of the bedrock;
- Type and characteristics of the ground water recipient in the biosphere;
- Construction and layout of the repository.

The repository is supposed to be placed in a region where the natural flow is essentially downwards. The natural travel paths will eventually turn upward and the contaminated water will eventually reach a creek, lake, or a well. The travel distance can vary and it is conceivable that under some circumstances the flow paths are rather short and in the order of a distance equal to the depth of the WPC repository.

A schematic view of such a flow scenario is shown in Figure 13-1.

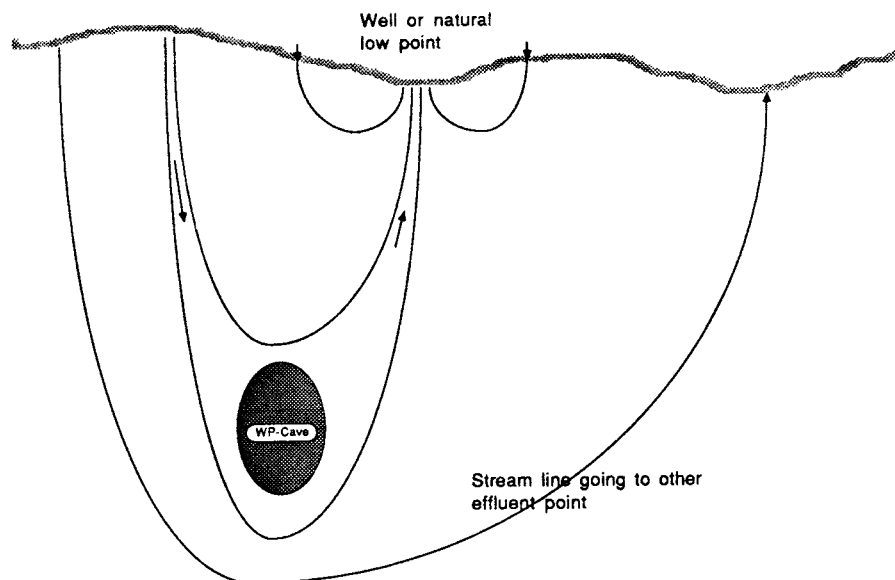

Figure 13-1. Schematic illustration of the ground water flow field at a site where the natural flow is directed downwards.

Dilution volumes were calculated in the KBS-3 study /KBS-3, 1983/ but differences exist between the KBS-3 design and the WPC design which make it difficult to just adopt the values used in the KBS-3 study. The most important differences concern the surface area in the horizontal plane, the depth of repository location, and the hydraulic cage structure in the WPC design. In order to avoid a detailed analysis of site specific ground water parameters of importance to the WPC design in the present study, the target concerning dilution in wells was instead set to be to consider a span of values. The high dilution volume is taken from the KBS-3 study and the low dilution volume is taken from a scenario, further described below, with a very low dilution assuming that all the radionuclide contaminated water from the repository goes to one small well.

13.2 DILUTION IN WELL USED FOR KBS-3 DESIGN

In this section only a summary of the presentation in the KBS-3 /1983/ is included.

A general illustration of the flow field around the KBS-3 repository is shown in Figure 13-2.

The repository has a horizontal surface area of about 500 000 m². The shortest distance to a high-permeable zone (in contact with ground surface) is estimated to be 100 m. Different ground water parameters, observed in field measurements at several sites, were used in calculations of water turnover and ground water reservoirs. The result was that from a depth of 500 m the water flowing

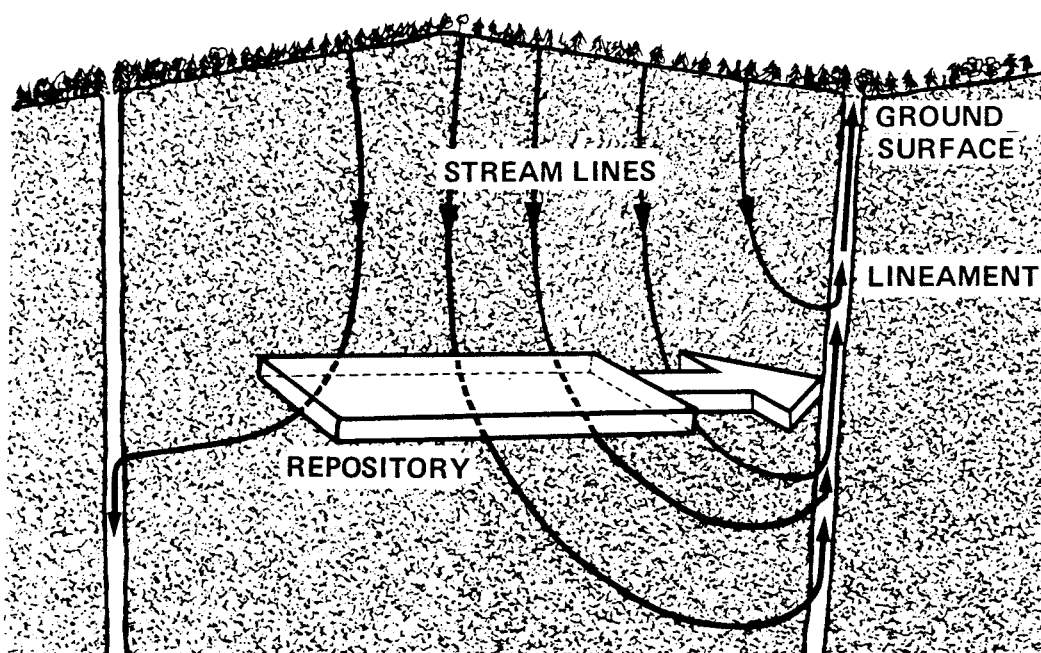

Figure 13-2. Schematic illustration of the flow field around a KBS-3 repository. The unfilled arrow shows the simplified model with the entire repository located at a distance of 100 m from the fracture zone and a direct horizontal flow from the repository to the fracture zone.

through the repository is diluted 30 000 to several million times before reaching man via water in a surface well. The water volume through the repository was estimated to be 50 m³ based on a ground water flow of 0.1 l · m⁻² · a⁻¹ at 500 m depth. With the aim of choosing a conservative figure in the KBS-3 study a volume of 500 000 m³ of water was chosen as the recipient for the annual release of nuclides in the base case. The reservoir was determined to comprise 250 000 m³ of water with a turnover of two times per year.

For the WPC design the same dilution was judged to be the most favourable one without going into further detailed analysis on the impact of the design in the KBS-3 calculations.

13.3 DILUTION FROM WPC IN ONE VERY SMALL WELL

13.3.1 Release from Repository

In assessing the changing concentration of the nuclides, their release mode and the concentration in the near field, as well as the possible flow patterns, are of concern.

Two important release modes have been identified. The first is by water flowing through the repository. The flowing water will carry the nuclides out with a concentration equal to that in the repository at that time. The “flow through” release mode is clearly dominating during the thermal period for the properties of the bentonite/sand barrier consistent in the studied cases. The flow rate through the repository is as large as $Q_{eq}^T = 70 \text{ m}^3 \cdot \text{a}^{-1}$ at most. It may be noted that the flow rate of water in the rock at mid-height of the repository has been estimated to be 0.3 l · m⁻² · a⁻¹. This means that if a flow of 70 m³ per year was to reach the far field without dilution by diffusion or physical mixing, it would flow in a cross sectional area of about 230 000 m². After the thermal period the release is also dominated by the flow through mode. The flow rate of contaminated water, if the bentonite/sand barrier is considered alone and not in combination with the hydraulic cage, is about 11 m³ · a⁻¹. This volume would flow through a stream tube with a cross section of about 37 000 m² of rock at a depth where the flux is 0.3 l · m⁻² · a⁻¹.

The second release mode is by diffusion through the bentonite/sand barrier and into the slowly moving water passing the back-fill. This is called the “diffusion mode”. The release is limited by the rate of diffusion into the water moving in the narrow fractures in the rock. The release rate in this case can be visualized in the same way as in the “flow through” case. The equivalent water volume contaminated to the concentration which is momentarily in the repository is called Q_{eq} . In reality the contaminated water volume is larger and has a lower concentration the further away from the back-fill it is. The notion of an equivalent flow rate is very useful because it allows the direct comparison with the “flow through mode” and also is easy to visualize. In reality the concentration is high nearest to the back-fill and decreases outward. 99% of the nuclides will reside in a water volume $4 \cdot Q_{eq}$. In the Low Flow Through Case $Q_{eq} = 0.91 \text{ m}^3 \cdot \text{a}^{-1}$. This is the flow rate in about 3 000 m² in the rock at repository depth. The figure applies as well for the case where there is no hydraulic cage present. The cage will decrease the release as is discussed later in this chapter.

One of the crucial questions is whether the contaminated water is mixed with and diluted in larger volumes of ground water or not. For flow in a homogeneous porous medium, the transverse dispersion and dilution can be readily calculated. The rock is, however, not such a medium and the flow is in this study assumed to take place in channels, which are few and far apart. Over short distances at least

the channels may not intersect and mix their waters although some dilution may take place by diffusion into stagnant or slowly moving zones of water.

13.3.2 Concentration in Water Leaving Repository Near Field

The flow in channels is considered to be laminar and there are no eddies to help mixing different bodies of water. To illustrate the extent of mixing the following example is used. In a channel, one meter wide, the contaminated water flows with an even velocity. The channel in its full extent comes in an edge contact with another channel of like dimensions and flow rate of non contaminated water. As the two bodies of water come in contact the nuclide from the contaminated stream starts to diffuse into the pure water. Fick's second law applied to this case shows that it takes about one year for 10% of the nuclides to diffuse from one stream to the other. Over times of 10 to 100 years the two streams would be well mixed. The water residence time to the ground level in the fast pathways, which also may carry a large part of the nuclides, is probably in the latter time range. This means that during the shorter residence times in the near field dilution effects are negligible between channels in the same fracture plane. At fracture intersections where the channels have been noted to be narrow mixing may be more effective. At present not enough is known of channel statistics to make detailed calculations. With the present knowledge even during the transit to the ground surface the dilution underway cannot be expected to be large as long as the water flows in the channels of the rock only. If the water flows in the hydraulic cage the situation may be somewhat different.

13.3.3 Influence of Hydraulic Cage

If the contaminated water enters the water which flows in the hydraulic cage, the diffusion distances are shorter and the residence times longer. The presence of the cage will decrease the flow rate of water that is contaminated and give an overall smaller release.

The flow rate of water in the cage with dimensions about 100 m by 300 m (projected area of some 30 000 m²) is on the order of 27 m³ · a⁻¹ if one accounts for the increased draw in of water from surrounding rock to a considerably more permeable region. If the cage was to act as an infinitely permeable sphere, it would draw in a water flow rate more than two times higher than would flow in the cross section taken up by the sphere having the same conductivity as the surrounding rock /SKB, 1989/. It may be assumed that the waters in the cage are well mixed because of the long residence time and narrow spaced drill holes. The nuclides leaving the cage will thus be diluted in nearly 27 m³ · a⁻¹. This is about a 45 times higher flow rate than the original and the concentration is proportionally less.

The cage ensures that the contaminated water flows in the channels with the highest flow rates which are probably also those which will have the smallest residence times in the far field.

13.4 RELEASE TO A WELL

It is assumed that wells in the future, as now, will often be drilled as close as possible to cottages or farmhouses, most probably in a fracture zone, or intersecting a zone with enhanced hydraulic conductivity. The maximum depth of a local

“farmhouse well” is dependent on the relative costs of pumping water horizontally and drilling a deep well in the rock. Assuming the present cost balance to be applicable in the future, local wells deeper than 100 m will be few. A working well will probably not be drilled deeper than to the level where it has water bearing structure of acceptable size, be it a fracture zone or a water bearing channel. Most of the water to the well will come from infiltration from above lying rock but some flow may be drawn into the well from deeper lying rock. If the capacity of the well is large and if it is unsuitably located in relation to the repository, all the contaminated water may be drawn into the well. In the well it will be mixed with all the other water drawn into the well. To cover the possible dilution span it is necessary to explore the possibility that a well of a small capacity may draw in most or all of the nuclides and not allow for a large dilution. It is possible to envisage cases where a well is drilled in the natural outflow area of the water from the repository. The stream tube with the contaminated undiluted water is naturally flowing to the place where the well is drilled with the result that all nuclides released from the repository end up in this well. The scenario is easily conceived if the rock is a porous medium. The stream tube, which is large at repository depth where the flux is small, will be compressed to a thin tube if no dilution occurs when it comes to areas with large fluxes in the rock close to surface. Figure 13-1 illustrates this process.

The presence of channels in the rock does not influence this analysis because the stream tube may be seen as a channel or it may contain several channels. As long as all the channels go to the same well the result is the same.

If there is a well which is in the vicinity of or in contact with the channels with the contaminated water it will draw in the contaminated water and dilute it in all the water of well. A small capacity well will thus have a higher concentration than a large well if one channel intersects the well.

The size of a very small well has not been investigated. For the purpose of this study the well has been assumed to have a catchment area of 20 000 m² and the surface rock an infiltration rate of 0.1 m³·m⁻²·a⁻¹. This will result in a capacity of 2 000 m³ of water per year (6 m³ per day).

13.5 CONCLUSIONS

Two alternative dilution scenarios are considered for the well:

- Large Dilution, i e annual release is diluted in 500 000 m³ of water;
- Small Dilution, i e annual release is diluted in 2 000 m³ of water.

14 SITE SPECIFIC QUESTIONS

This chapter discusses the existence of flat zones with a high hydraulic contrast to the surrounding bedrock and their frequency of occurrence. Data on such fracture zones have just recently been compiled on an initial basis and the conclusions are therefore only general.

14.1 GENERAL

The presented analysis on the WPC assumes a relatively homogeneous rock mass with a hydraulic conductivity that slowly decreases with depth.

From general observations on the sites investigated within the frame of the program for site characterization concerning nuclear disposal, as well as site investigations motivated by other reasons, it has been known that gently dipping zones with higher conductivity than the surrounding rock exist and often frequently. The properties of such zones have, however, not been possible to measure until recently with the help of radar measurements and hydraulic interference tests. Some information, therefore, does exist today but only to a limited extent.

14.2 EFFECT ON WPC

Fracture zones, which are intersected by a WPC repository, must have a relatively large extension in order to increase the release rate of nuclides in any significant way. It is, therefore, not the smaller zones which are to be focussed on, but the major ones, which are easy to detect at site characterization.

In the course of this study a significant increase of nuclide releases has been considered to be caused by a zone with a width of about 30 m (10% of WPC height) and a hydraulic conductivity that is 100 times higher than the surrounding rock. If the hydraulic contrast is 1 000 times, then a zone width of about 10 m leads to the same increase of the nuclide release rate. The intersected zone is schematically shown in Figure 14-1.

14.3 PRELIMINARY INFORMATION ON EXISTENCE OF GENTLY DIPPING FRACTURE ZONES

The type of zones, as defined above, are characterized as "fracture zones", a term which denotes a planar domain of closely spaced fractures with an enhanced frequency of fractures. The zones are situated in crystalline rock. They have generally been formed during the course of tectonic movements, and thus reflect an event of deformation in the geosphere. The approach of interpretation of the character of fracture zones often gives information on the extension of the zones and their interconnection with other structures related to their formation. Gently dipping tectonic zones may either be normal faults or thrusts. The tectonic regime may either be extension, contraction, or a wrench/transform fault. Contraction/extension tectonics form analogous structures, often with a

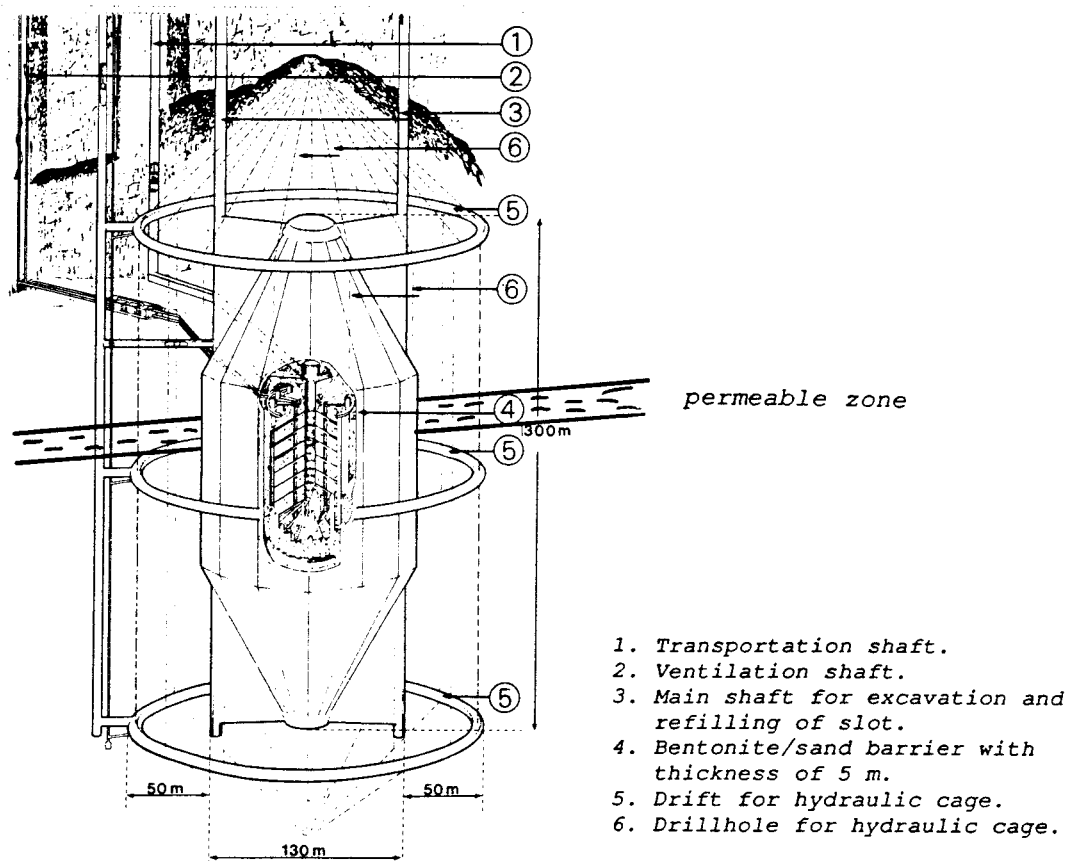

Figure 14-1. Permeable zone intersected by a WPC.

subhorizontal basalt fault plane. Wrench faulting regimes have an inclined, often a subvertical root zone. The fracture zones are typically spoon-shaped implying that steeply dipping zones at the surface may become gently dipping at depths.

“Non-tectonic” occurrence of fracture zones is sheet intrusions (e.g., aplite/pegmatite dykes) and layered rock sequences with inlayers of porous beds.

The compilation of information from different sites in Sweden has indicated that it is very probable to find a flat dipping highly conductive zone with properties that could double the release of radionuclides from a WPC or increase the release even more. This conclusion is based on some geophysical measurements showing the interconnection between structures in different boreholes, but also on interpretation of the tectonic history of the considered sites.

The scope of sites comprises nine that have been characterized with respect to properties of importance to nuclear waste disposal. Information has also been included from the Dannemora and Stripa mines as well as the SFR- and CLAB sites. At those sites information has been achieved to a maximum depth of 800 m. The Siljan drillhole, also considered, is much deeper but the information available is vague. The summary of the results is presented in Table 14-1.

Only two of the sites are free of the defined type of fracture zones which, when intersecting the WPC, would have an impact on the release rate of radionuclides. At the other sites the existing zones can be expected to limit the possibilities of locating several WPCs in a farm, if not the safety criteria tolerates that the WPCs repository is intersected by the zone(s).

Table 14-1. Available data on gently dipping fracture zones at sites in Sweden.

Site	FRACTURE ZONE					Comments
	Width m	Dip	Hydraulic contrast to surround- ing rock	Distance between fractures m	Extension m	
Finnsjön	100	16°	10 ³ –10 ⁴	~ 500	—	100–1 000 m depth.
Fjällveden	—	—	—	—	—	No zone identified.
Gideå	50	30°	10 ¹ –10 ³	—	> 2 000	One zone, traced to 250 m below surface.
Kamlunge	25–50	0°	10 ² –5·10 ²	> 550	> 900	One zone at 550 m depth.
Klipperåsen	70	—	10 ⁵	—	—	One zone at 740–810 m depth.
Kråkemåla	25	—	10 ³	200–300	—	Only one out of three traced has the high hydraulic contrast.
Sternö	—	—	—	—	—	No zone identified.
Svartboberget	25–50	—	> 10 ²	150–350	> 2 000	12 zones identified.
Ävrö	150	20–40°	> 10 ²	—	—	One zone at 408–578 m depth (in one borehole)
Dannemora	—	—	—	300–500	—	Two systems of fault zones dipping 60–85°.
Stripa	< 10	35–40°	10 ²	25–45	—	Three zones indicated on 360 m level.
CLAB	—	—	—	—	—	No zone down to 100 m level.
SFR	3–16	—	10 ²	—	—	Zone H2 at 150 m depth.

Except for the increased nuclide release rates caused by the fracture zones, the combination of one or several of such zones and the hydraulic cage may very well in itself lead to a higher dose exposure to man. The reason is that the occurring flat fracture zones very often outcrop in topographical lows. Man, who in the future finds water, is likely to find it in an existing fracture zone, a zone which in our case has been intersected by the hydraulic cage. It is probable that the head in the fracture zone is lower than the head in the surrounding rock, and the fracture zone will drain the rock. The hydraulic cage around the WPC will balance the hydraulic head around the repository. The balanced hydraulic head will most likely be equal to or somewhat higher than the hydraulic head in the gently dipping fracture zone. As the hydraulic cage provides a large reservoir of water which is more easily available than the water in the bedrock, the fracture zone might drain the WPC repository only.

14.4 CONCLUSIONS

From the preliminary data on the existence of gently dipping fracture zones it is clearly indicated that the bedrock at most sites contains fracture zones which are difficult to avoid for a WPC structure, and which would cause an important addition of radionuclide releases from the near field. This addition has, however, not been considered in the calculation of releases as the fracture zones are site specific and no specific site has been considered in the study of the WPC so far.

In order to avoid fracture zones, the location of the WPC is indicated to be limited. Suitable sites are foreseen to be restricted, as for one thing the vertical distance between fracture zones with an impact on the peak dose rate to man must be greater than the height of the WPC structure. In general this means that the location of the WPC is less flexible than originally considered.

If on the other hand a fracture zone is considered to be acceptable, this judgement must include the evaluation of the higher possibility for the low dilution case.

15 RELEASE OF RADIOACTIVE SUBSTANCES

In this chapter a summary is given of the calculations made of the radionuclide transport from the fuel through the near field, far field and biosphere. Basic input data to the calculations are compiled in Appendix 4.

15.1 RADIONUCLIDE MIGRATION TO OUTSIDE OF BENTONITE/SAND BARRIER

15.1.1 General

Water breakthrough in all the canisters is assumed to occur 200 years after repository closure. The fuel is then 340 years old as a result of the pool storage period in the CLAB facility and the dry storage period. The radionuclides that in the long term will be released in such amount that they may be important to the dose to man have been identified. The concentrations of these radionuclides in the fuel (PWR, 38GWd(tU)⁻¹) at the time 300 years after discharge from the reactor are given in Table 15-1. These data were used to define the inventory at the time for canister breakthrough

15.1.2 Calculation Model

The simplified system for which the calculations were performed is schematically shown in Figure 15-1. The two barriers considered were the refilled ground

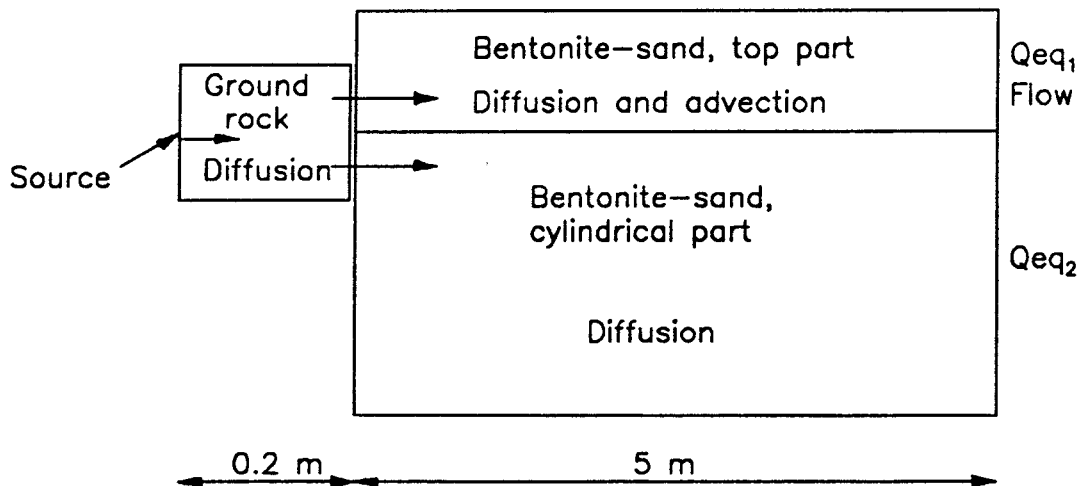

Figure 15-1. Schematic illustration of the calculation model.

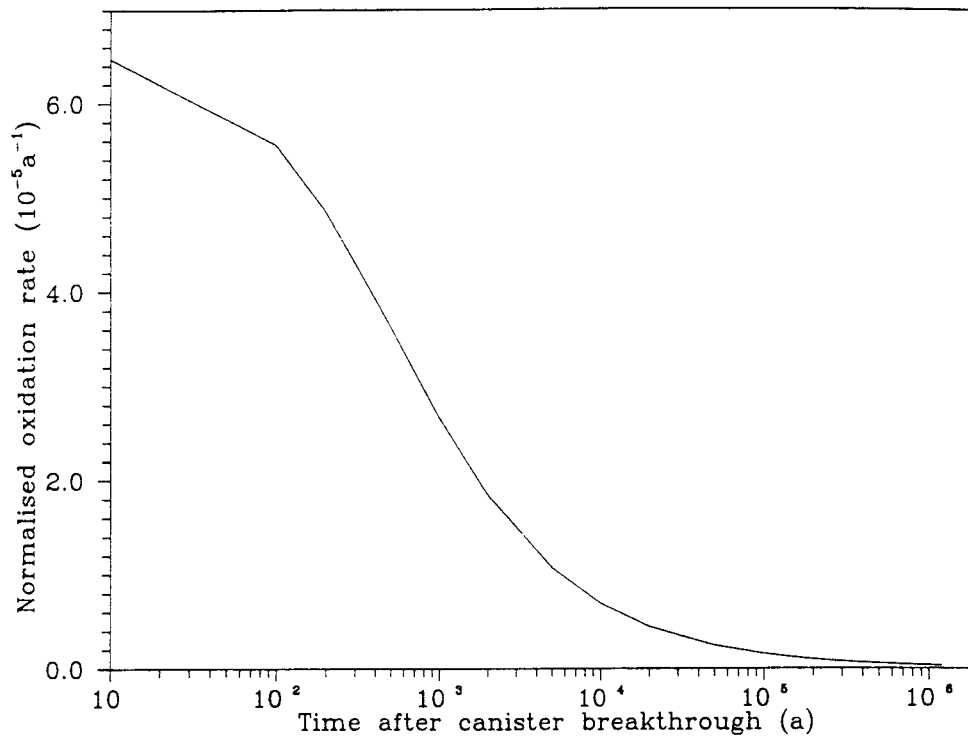

Figure 15-2. Normalized radiolytic fuel oxidation rate.

rock surrounding the canisters and the bentonite/sand barrier. The nuclide migration was modelled as one-dimensional transport through two flat barriers in series, with two parallel pathways through the second barrier representing transport through the top of the bentonite/sand barrier and through the cylindrical part respectively. This simplification was made since the design of a WPC is symmetric and the curvature of the ground rock barrier and the bentonite/sand barrier can be neglected.

The source term for the migration through the barriers, i.e. the nuclide concentration outside the canister surface, was calculated from the radiolytic fuel oxidation rate, see Figure 15-2, and the inventory at canister breakthrough, see Table 15-1. For the solubility limited nuclides the source term was set equal to the solubility under reducing conditions. Information about solubilities at 100–150°C is very scarce. Therefore solubilities in granitic ground water representative for temperatures around 20°C were used, see Table 15-2. The solubility applied for Nb is the concentration in equilibrium with solid $\text{Ca}(\text{NbO}_3)_2$. Under prevailing conditions it is more likely that the solid phase is Nb_2O_5 , which has a considerably lower solubility [I. Grenthe, personal communication]. The solubility used for Pd presumes PdO as the solid phase. If instead solid $\text{Pd}(\text{OH})_2$ determines the concentration, a higher solubility than the value given in Table 15-2 should be applied. The release rate of Pd-107 from the bentonite/sand bar-

rier can, however, not exceed the release rate obtained when the concentration outside the canister surface is determined by the radiolytic fuel oxidation rate. This release rate has been calculated to be about 8 000 times higher than the solubility limited release rate /Lindgren and Skagius, 1989/. The maximum dose rate would then be about 8 000 times higher than the value given for Pd-107 in Table 15-15. The contribution to the total dose rate is in both cases negligible.

Table 15-1. Important radionuclides.

Nuclide	Half life (a)	Concentration in 300 years old fuel	
		g · (tonnes fuel) ⁻¹	GBq · (tonnes fuel) ⁻¹
Fission and activation products			
C-14	5 730	0.16	25.7
Ni-59	75 000	49.5	148
Se-79	65 000	6.61	17.0
Zr-93	1.5 · 10 ⁶	803.6	74.7
Nb-93m	*	6.8 · 10 ⁻³	71.0
Nb-94	20 000	8.9 · 10 ⁻⁴	0.006
Tc-99	214 000	867.8	544.6
Pd-107	6.5 · 10 ⁶	280.2	5.3
Sn-121m	54.9	6.4 · 10 ⁻⁵	0.1
Sn-126	100 000	32.1	33.7
Sb-126m	*	1.2 · 10 ⁻⁸	33.7
Sb-126	*	1.5 · 10 ⁻⁶	4.7
I-129	16 · 10 ⁶	206.6	1.4
Cs-135	3 · 10 ⁶	342.2	14.6
Actinides and daughters			
Pu-242	376 000	751.1	106.2
Pu-240	6 570	1 615	1.36 · 10 ⁴
Pu-239	24 100	4 669	1.07 · 10 ⁴
Np-237	2.14 · 10 ⁶	1 134	29.6
Pa-233	*	3.8 · 10 ⁻⁵	29.6
U-238	4.47 · 10 ⁹	9.4 · 10 ⁵	11.7
Th-234	*	1.4 · 10 ⁻⁵	11.7
Pa-234m	*	4.6 · 10 ⁻¹⁰	11.7
U-236	23.4 · 10 ⁶	4 160	10.0
U-235	7.04 · 10 ⁸	6 465	0.52
Th-231	*	2.6 · 10 ⁻⁸	0.52
U-234	245 000	361.6	83.7
U-233	159 000	0.081	0.029
Th-232	14.1 · 10 ⁸	0.036	1.5 · 10 ⁻⁷
Ra-228	*	1.7 · 10 ⁻¹¹	1.5 · 10 ⁻⁷
Ac-228	*	1.8 · 10 ⁻¹⁵	1.5 · 10 ⁻⁷
Pa-231	32 800	2.3 · 10 ⁻³	4.0 · 10 ⁻³
Th-230	80 000	0.25	0.19
Th-229	7 300	4.7 · 10 ⁻⁵	3.7 · 10 ⁻⁴
Ra-226	1 600	2.9 · 10 ⁻⁴	0.011
Pb-210	*	3.0 · 10 ⁻⁶	8.5 · 10 ⁻³

* Daughter in equilibrium with parent nuclide.

The transport through the ground rock surrounding the canisters was modelled as diffusion with simultaneous sorption. Granite sorption data representing reducing conditions, mainly taken from KBS-3 /1983/, were used, see Table 15-3. The porosity of the ground rock barrier was assumed to be 30 %, and the pore diffusivity was set to $2 \cdot 10^{-9} \text{ m}^2 \cdot \text{s}^{-1}$.

Table 15-2. Solubilities used in the calculations, reducing conditions, room temperature, and neutral pH.

Element	kg · m ⁻³	Reference
Ni	$6 \cdot 10^{-3}$	Neretnieks and Andersson, 1978
Se	$8 \cdot 10^{-5}$	Karlsson, Höglund, Pers, 1986
Zr	$9 \cdot 10^{-9}$	Baes, Mesmer, 1976
Nb	$1 \cdot 10^{-4}$	Andersson, Torstenfelt, Rydberg, 1979
Tc	$2 \cdot 10^{-7}$	KBS-3, 1983
Pd	$2 \cdot 10^{-8}$	Karlsson, Höglund, Pers, 1986
Sn	$1 \cdot 10^{-4}$	Karlsson, Höglund, Pers, 1986
Am	$6 \cdot 10^{-3}$	KBS-3, 1983
Pu	$8 \cdot 10^{-6}$	KBS-3, 1983
Np	$8 \cdot 10^{-6}$	KBS-3, 1983
U	$1 \cdot 10^{-5}$	KBS-3, 1983
Th	$4 \cdot 10^{-7}$	KBS-3, 1983

* solubility under oxidizing conditions. This value was used because the solubility of Pu is lower under oxidizing conditions which means that the concentration is unaffected by the change from oxidizing to reducing conditions.

Table 15-3. Sorption data, room temperature, and neutral pH.

Species	Sorption coefficient, (m ³ · kg ⁻¹)	
	Granitic rock red. (ox.) conditions	10/90 bentonite/sand oxidizing conditions
C	0	0
Ni	0.2	0.025
Se	0.001	0.0003
Zr	4	0.4
Nb	4	0.1
Tc	0.05 (0.0002)	0.0005
Pd	0.001	0.0005
Sn	0.001	0.0005
I	0	0.0003
Cs	0.05	0.025
Am	5	1.3
Pu	5	0.1
Np	5 (0.1)	0.013
U	5 (0.05)	0.006
Pa	5	0.3
Th	5	0.3
Ra	0.1	0.09

The nuclide transport through the cylindrical part of the bentonite/sand barrier was modelled as diffusion. Due to lack of data on sorption in bentonite/sand mixtures under reducing conditions, data used in the SFR-study /Wiborgh and Lindgren, 1987/ on sorption in 10/90 bentonite/sand mixtures under oxidizing conditions were also applied in this study, see Table 15-3. The porosity of the barrier was set to 25%, and the pore diffusivity to $4 \cdot 10^{-10} \text{ m}^2 \cdot \text{s}^{-1}$, also this in accordance with the SFR-study. The convective boundary condition at the outlet of the cylindrical part of the barrier was expressed in terms of the equivalent water flow Q_{eq} , that enters the barrier at the upstream side with zero concentration and leaves the barrier at the downstream side with a concentration equal to the concentration at the outlet boundary of the cylindrical part of the barrier. With a flow rate of $0.3 \text{ l} \cdot \text{m}^{-2} \cdot \text{a}^{-1}$ of the ground water passing along the outside of the barrier, which is representative for ground water flow at 200 meters depth in Swedish rock, and a flow porosity of 10^{-3} in the rock outside the barrier, the equivalent water flow outside the cylindrical part of the barrier is on the order of $1 \cdot \text{m}^3 \cdot \text{a}^{-1}$.

Through the top part of the bentonite/sand barrier the transport was modelled as simultaneous advection and diffusion. In the Low Flow Through Case the advective transport is caused only by the thermo-induced flow. The thermo-induced flow is decreasing with time and after about 5 000 years the thermo-induced flow is so low that the advective transport through the top of the barrier is negligible compared to the diffusive transport. The nuclide transport from the barrier to the water flowing in the rock just outside the top of the barrier is then also dominated by diffusion.

In the High Flow Through Case the natural ground water flow through the barrier has to be considered. It was conservatively assumed that the natural gradient has the same direction as the thermal gradient, i e vertically upwards. The advective transport through the top of the barrier is then caused by both the thermally induced flow and flow induced by the natural gradient. The flow is decreasing with time due to the decrease in temperature gradient, but reaches a lower limit determined by the natural gradient over the repository. This means that the advective transport through the top of the bentonite/sand barrier determines the nuclide release from the top of the barrier.

The advective flow by which nuclides are transported through and released from the top of the bentonite/sand barrier used in the calculations is shown in Figure 15-3. The natural ground water flow through the top in the High Flow Through Case was calculated to $11 \text{ m}^3 \cdot \text{a}^{-1}$.

15.1.3 Release Rates from the Bentonite/sand Barrier

Release rates of the predominant nuclides from the bentonite/sand barrier as a function of time after canister breakthrough, calculated for the Low Flow Through Case, are shown in Figure 15-4. These release rates are obtained when the radiolytic oxidation of the fuel determines the source term for all nuclides studied, i e no consideration has been taken to any possible solubility limitations in the concentration at the interface between the canisters and the ground rock. The maximum total release rate is obtained during the first 10^6 years, and is dominated by the non- or slightly sorbing C-14, Tc-99, Sn-126, and Se-79. At times longer than 10^6 — 10^7 years, these nuclides have decayed and the total release rate will decrease by more than two orders of magnitude. The predominant nuclides at longer times are the long lived uranium isotopes and Np-237.

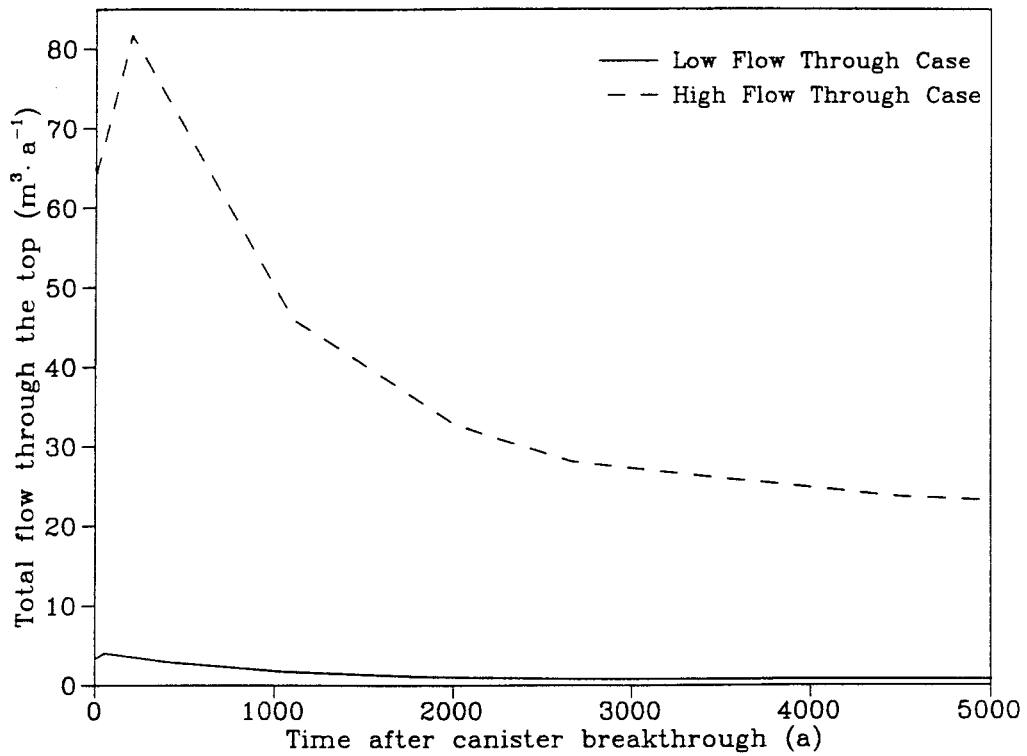

Figure 15-3. Total advective water flow through the top of the bentonite-sand barrier in the two cases studied.

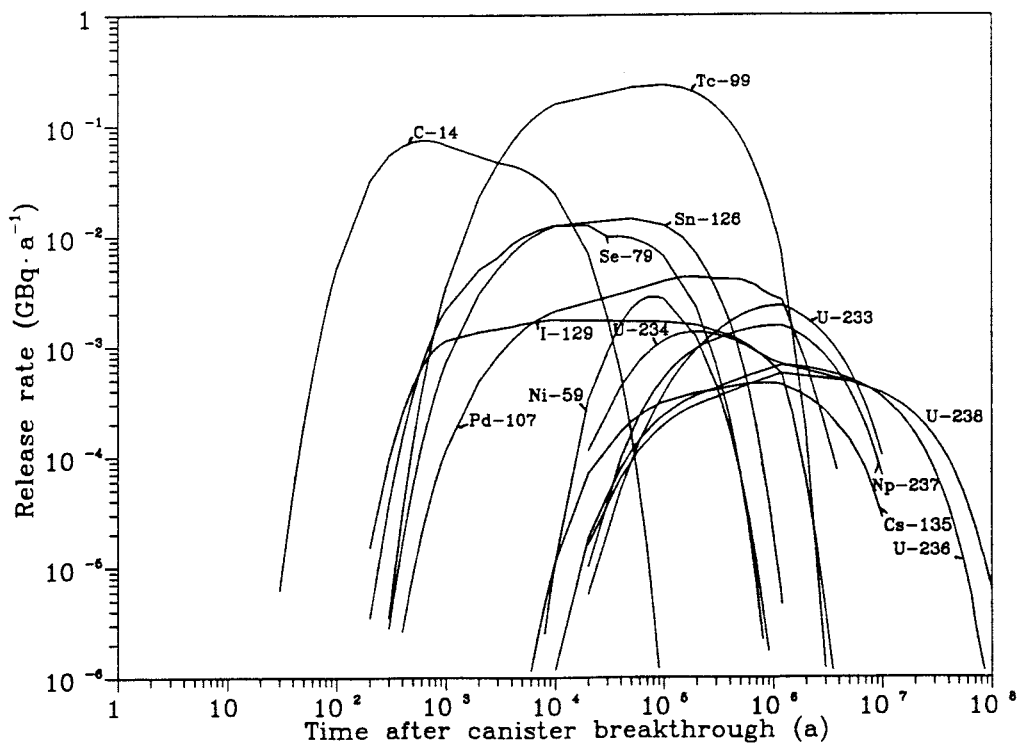

Figure 15-4. Low Flow Through Case results expressed as release rates from the bentonite-sand barrier. Solubility limitations are not considered.

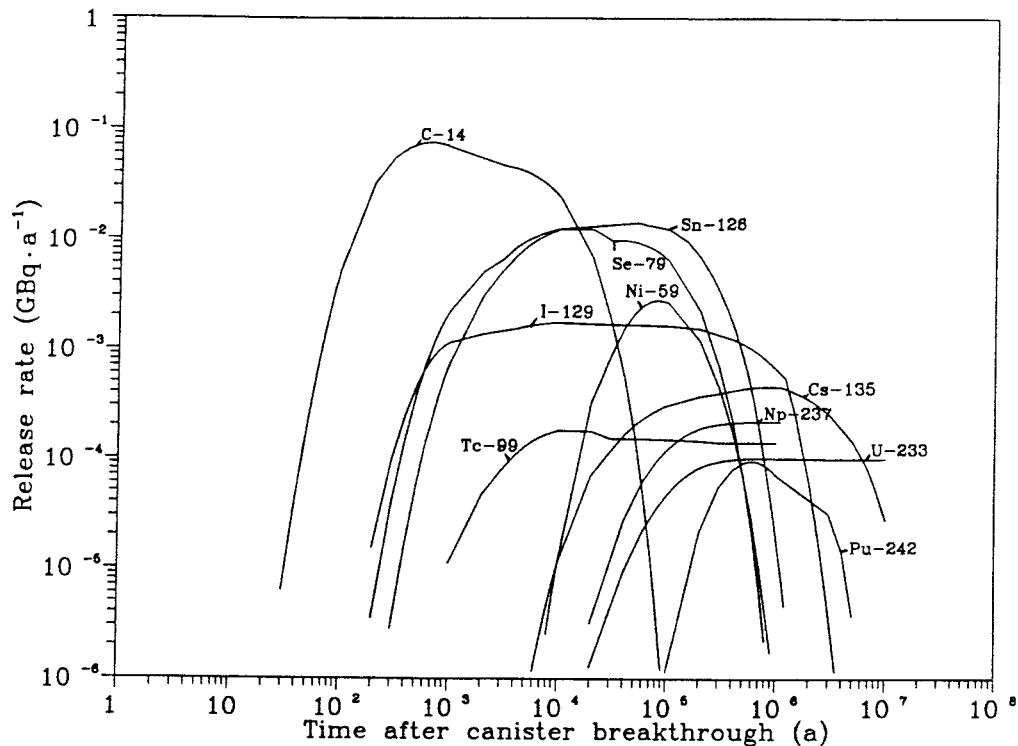

Figure 15-5. Low Flow Through Case results expressed as release rates from the bentonite-sand barrier. Solubility limitations are considered.

Many of the radionuclides are known to have a solubility limit. For a number of the nuclides studied the dissolution rate, determined by the radiolytic fuel oxidation rate, results in a concentration outside the canister surface that exceeds the assumed solubility of the nuclide. Nuclide release rates calculated for the Low Flow Through Case, when solubility limits are considered are shown in Figure 15-5. The release rates of Tc-99 and the parent and early daughter nuclides in the decay chains will be considerably lower when solubility limitations are accounted for. The release rate of C-14, Sn-126 and Se-79 are unchanged since they do not reach the solubility limit, or do not have any known solubility limit.

Release rates obtained for the High Flow Through Case are shown in Figure 15-6 for some important nuclides. Solubility limitations have been considered in the calculations. The higher flow rate through the top of the bentonite/sand barrier in this case results in higher release rates compared to the Low Flow Through Case. This is also shown in Table 15-4 where maximum release rates are given for both cases. Nuclides with relatively short half-life and/or low sorption in the barriers are most sensitive to the water flow through the bentonite/sand barrier. The immediate dissolution of 10% of the inventory of carbon and iodine also contributes to the large difference in maximum release rate of these nuclides between the two cases.

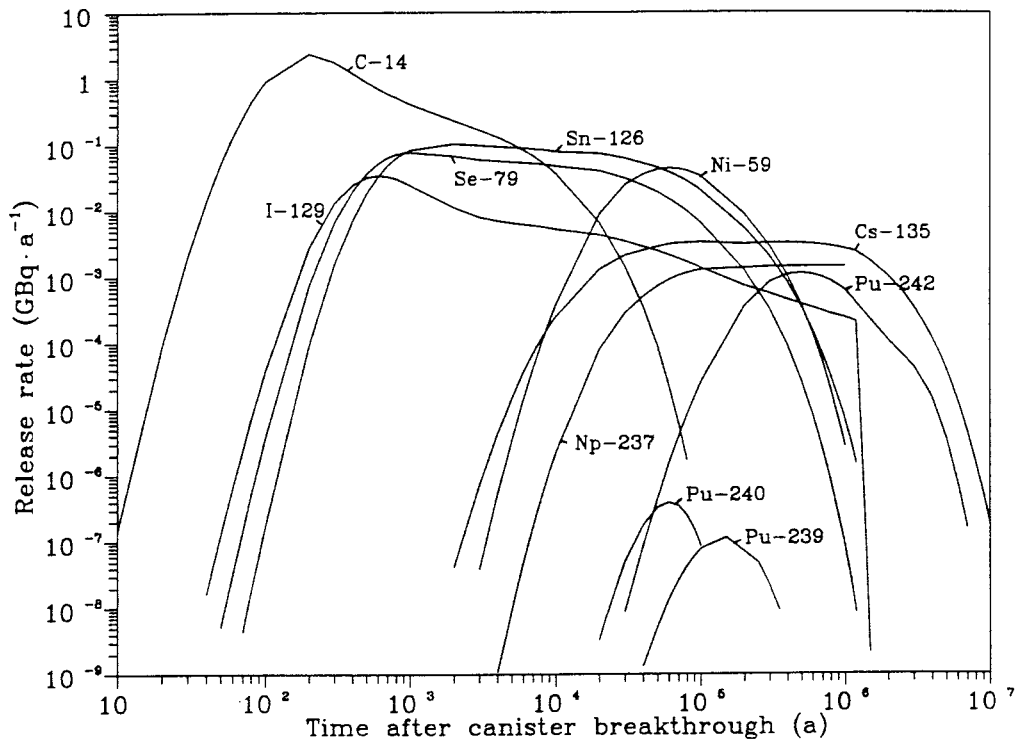

Figure 15-6. High Flow Through Case results expressed as release rates from the bentonite-sand barrier. Solubility limitations are considered.

Table 15-4. Comparison between the two cases studied. Solubility limitations are considered.

Nuclide	Maximum release rate, (Bq · a ⁻¹)		Ratio High Flow to Low Flow
	Low Flow	High Flow	
C-14	$7.4 \cdot 10^7$	$2.4 \cdot 10^9$	32
Ni-9	$2.8 \cdot 10^6$	$4.5 \cdot 10^7$	16
Se-79	$1.3 \cdot 10^7$	$7.7 \cdot 10^7$	6
Sn-126	$1.4 \cdot 10^7$	$1.0 \cdot 10^8$	7
I-129	$1.8 \cdot 10^6$	$3.4 \cdot 10^7$	19
Cs-135	$4.6 \cdot 10^5$	$3.4 \cdot 10^6$	7
Np-237	$2.2 \cdot 10^6$	$1.4 \cdot 10^6$	6
Pu-239	6.1	$1.1 \cdot 10^2$	19
Pu-240	15	$3.9 \cdot 10^2$	26
Pu-242	$9.6 \cdot 10^4$	$1.1 \cdot 10^6$	11

15.2 RADIONUCLIDE MIGRATION IN GEOSPHERE

15.2.1 Calculation Model

A transport model based on the channeling concept was used to calculate the release to the biosphere of nuclides escaping from the bentonite/sand barrier /Moreno et al., 1989/. In the model the rock is described as a bundle of independent channels each with its own flow rate and wetted surface. If the channel characteristics are known as well as the frequency of channels which carry a certain flow rate, the transport in every channel is calculated individually and the sum of the effluents is calculated by adding the effluent concentration of all channels, see Figure 15-7. Retardation in each channel due to sorption, diffusion into the rock matrix, and decay is included in the model. Hydrodynamic dispersion in the channels is, however, neglected because "dispersion" due to the flow rate distribution will be considerably larger than that due to hydrodynamic dispersion.

Data on channel frequency and the fraction of the total flow in each channel group were taken from the evaluation of observations in SFR. They are given in Table 15-5. The flow in each channel in the rock surrounding a WPC was obtained from the fraction of flow, the number of channels in each group, and the total flux in the rock surrounding a WPC which, as in the near field calculations, was assumed to be $0.3 \text{ l} \cdot \text{m}^{-2} \cdot \text{a}^{-1}$.

1.44
2
5.2.1.5

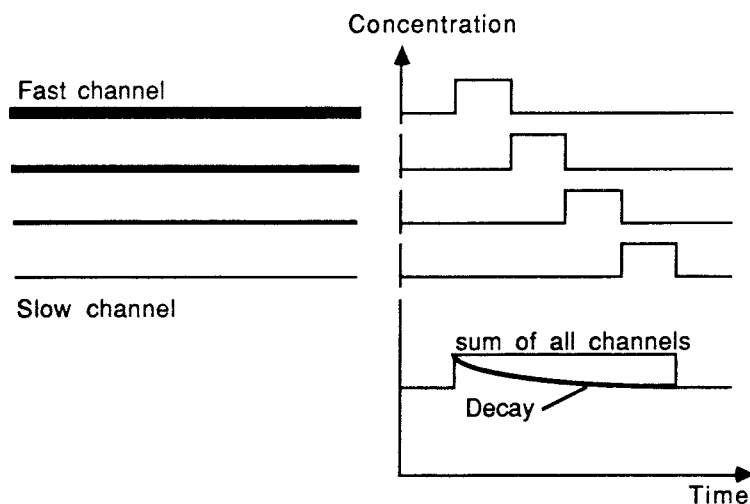
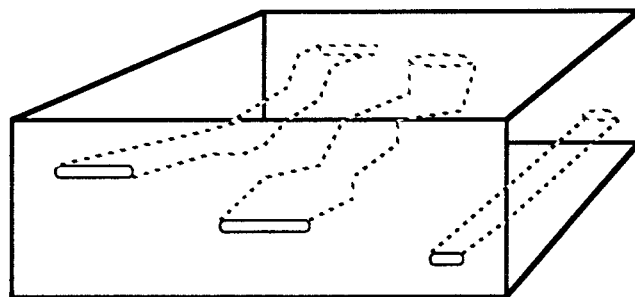

Figure 15-7. Illustration of the channeling model with no mixing between the channels.

Table 15-5. Fraction of the total flow rate that flows in the different groups of channels.

Flow rate range (l · min ⁻¹)	Fraction of channels	Fraction of flow rate	Flow rate per channel for a total flux of 1 l · m ⁻² · a ⁻¹ (m ³ · s ⁻¹ · 10 ⁻⁸)
≥ 1.6	0.012	0.131	2.940
0.8 — 1.6	0.024	0.148	1.653
0.4 — 0.8	0.073	0.207	0.772
0.2 — 0.4	0.250	0.305	0.333
0.1 — 0.2	0.232	0.126	0.149
< 0.1	0.409	0.083	0.056

In addition to the water flow the important parameters for the migration of radionuclides in rock are; the flow path length, the contact area between flowing water and rock, i.e. the wetted surface, sorption properties of the rock minerals, the porosity of the rock matrix, and the diffusivity in the rock matrix.

The flow path length or the length of the channels was set to 100 metres. This corresponds to either the shortest distance from the top of the hydraulic cage to the ground surface, or the shortest distance from the cave to a vertical fracture zone. The channels were further assumed to have a width of 1 metre and an aperture of 0.25 mm.

The sorption capacity of the rock was assumed to be the same as for the ground rock material used as back-fill in the canister channels for the case of reducing conditions in the far field, see Table 15-3. To cover the possibility of oxidizing conditions in the far field, calculations with sorption coefficients representative for oxidizing conditions were made for the redox sensitive technetium, plutonium, and uranium. These sorption coefficients are also given in Table 15-3. The effective diffusivity in the rock matrix was set to $5 \cdot 10^{-14} \text{ m}^2 \cdot \text{s}^{-1}$, which is a value that by a large number of experiments in the laboratory has been found to be representative for crystalline rocks.

The source term used in the calculation of the nuclide transport in the geosphere was the nuclide release rates from the bentonite/sand barrier obtained for the Low Flow Through Case. No calculations for the High Flow Through Case have been made. The hydraulic cage was not considered in the calculations, but a separate study of the possible effects of the hydraulic cage has been made. The results from this study are presented in Chapter 12 and Section 15.3.

15.2.2 Release Rates to the Biosphere

The results from the calculations show that very little retardation of the fission and activation products occurs in the rock over a travel distance of 100 metres and channel width of 1 metre. Only Nb-94, which exhibits strong sorption to the mineral surfaces and has a short half life, was notably decreased by retention and decay during the transport in the geosphere. The maximum release rate to the biosphere of Nb-94 was found to be about 10 times lower than the maximum release rate from the bentonite/sand barrier. The calculated release of Nb-94 from both near field and far field is, however, very small. The reduction in maximum release rate of the remaining fission and activation products was less than

a factor of 2. This is due to no or low sorption and/or long half lives of the fission and activation products.

The maximum release rate to the biosphere of nuclides participating in the chain decay is given in Table 15-6. These values are obtained if the nuclide concentration outside the canister surface is determined by the radiolytic fuel oxidation rate, i.e. no solubility limitations are taken into account. The ratio of the maximum release rate from the geosphere to the maximum release rate from the bentonite/sand barrier is also given in Table 15-6. The relationship between the maximum release rates from the near field (bentonite/sand barrier) and from the far field (geosphere) is illustrated in Figure 15-8.

Table 15-6. Maximum release rate to the biosphere and ratio of far field to near field release for nuclides participating in chain decay. Low Flow Through Case results when solubility limits not are considered.

Nuclide	Max. release rate (Bq · a ⁻¹)	Time (a ⁻¹)	Ratio far field to near field release
Decay Chain 4N			
Pu-240	10	7.0 · 10 ⁴	0.09
U-236	4.3 · 10 ⁵	2.5 · 10 ⁶	0.64
Th-232	44	3.0 · 10 ⁷	1.47
Decay Chain 4N+1			
Np-237	8.8 · 10 ⁵	1.3 · 10 ⁶	0.59
U-233	1.2 · 10 ⁶	1.3 · 10 ⁶	0.52
Th-229	1.0 · 10 ⁶	1.3 · 10 ⁶	22.2
Decay Chain 4N+2			
Pu-242	8.5 · 10 ⁴	7.0 · 10 ⁵	0.42
U-238	3.8 · 10 ⁵	4.5 · 10 ⁶	0.67
U-234	5.1 · 10 ⁵	4.0 · 10 ⁵	0.36
Th-230	2.4 · 10 ⁵	5.0 · 10 ⁶	10.4
Ra-226	5.0 · 10 ⁸	6.0 · 10 ⁶	10.4
Decay Chain 4N+3			
Pu-239	9.7 · 10 ³	1.6 · 10 ⁵	0.16
U-235	3.0 · 10 ⁴	3.0 · 10 ⁶	0.68
Pa-231	3.0 · 10 ⁴	3.0 · 10 ⁶	36

The reduction in maximum release rate caused by sorption and decay during the geosphere transport is less than one order of magnitude for the parent and early daughter nuclides. The higher release rate of late daughter nuclides from the far field compared to the near field release rate is because the main production of the late daughters occurs during the transport in the geosphere. As a consequence the late daughters, Ra-226 and Th-229, together with U-233 and Np-237 will be the predominant nuclides released to the biosphere at times longer than 10⁶ years. The level of the release rate of these nuclides is, however, more than one order of magnitude lower than the release rates of C-14 and Tc-99 which are the nuclides that will dominate the release to the biosphere during early times.

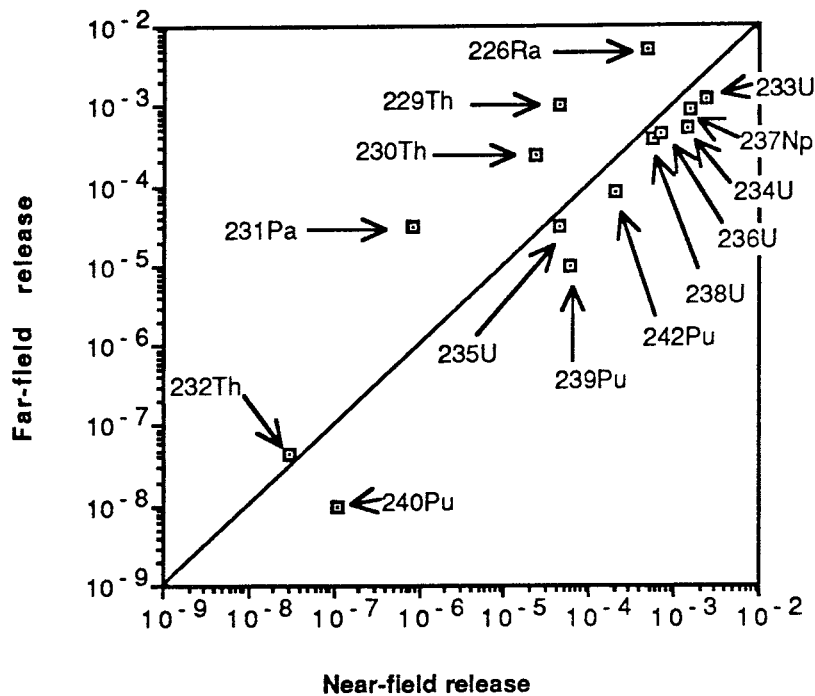

Figure 15-8. Release from the far field compared to release from the near field. Low Flow Through Case results. Solubility limitations are not considered.

Solubility limitations will reduce the release rates from the bentonite/sand barrier of some of the fission and activation products and of all the actinides and daughters. Consequently, the release rates to the biosphere of these nuclides will be lower when solubility limits are considered. The maximum release rate to the biosphere of the solubility limited Tc-99 and Pd-107 will be about the same as the maximum release rate from the bentonite/sand barrier due to the very small retention in the geosphere of these nuclides. An example of the effect of the retention in the geosphere for solubility limited actinides and daughters is given in Table 15-7 as the maximum release rate to the biosphere of nuclides in Decay Chain 4N+2. Taking solubility limitations into account will reduce the maximum release rate to the biosphere with more than three orders of magnitude, except for Pu-242. This is mainly a result of the lower release rates from the bentonite/sand barrier. A lower release rate from the bentonite/sand barrier of parent and early daughter nuclides as a consequence of solubility limitations also means that a smaller amount of late daughter nuclides is produced by decay during the transport in the geosphere. For Th-230 and Ra-226 this means a considerable decrease in the ratio of the far field to near field release, Table 15-7.

If the environment in the geosphere is oxidizing instead of reducing less sorption of technetium, uranium, and neptunium will occur. The effect of the geosphere as a barrier for these nuclides and their daughters will in this case be still less important.

Table 15-7. Maximum release rate from the far field and ratio of far field to near field release for nuclides in Decay Chain 4N+2. Low Flow Through Case results. With, (A), and without, (B), solubility limitations.

Nuclide	Maximum release rate (Bq · a ⁻¹)		Ratio far field to near field maximum release rate	
	A	B	A	B
Pu-242	4.1 · 10 ⁴	8.5 · 10 ⁴	0.42	0.42
U-238	1.2 · 10 ²	3.8 · 10 ⁵	0.92	0.67
U-234	2.1 · 10 ²	5.1 · 10 ⁵	0.31	0.36
Th-230	1.0 · 10 ²	2.4 · 10 ⁵	0.29	10.4
Ra-226	3.0 · 10 ³	5.0 · 10 ⁶	2.50	10.4

The calculations made of the nuclide migration in the geosphere have shown that the retardation and decay of nuclides over a transport distance of 100 metres will be of minor importance. The maximum release rate to the biosphere will be, in general, about 50 % of the maximum release rate from the bentonite/sand barrier. For sorbing nuclides with short half lives the transport through the geosphere will result in a somewhat larger reduction of the release from the bentonite/sand barrier. For long lived nuclides the near field and far field release will be almost equal.

15.3 HYDRAULIC CAGE

The presence of the hydraulic cage will reduce the natural ground water flow but not the thermally induced water flow in the rock inside the cage. The relative importance of the natural ground water flow and the thermally induced flow are different in the Low Flow Through Case compared to the High Flow Through Case. The effect of the hydraulic cage will therefore be different in these two cases.

In the Low Flow Through Case the thermally induced flow is of minor importance. The nuclide release from the bentonite/sand barrier occurs only by diffusion to the natural ground water flow passing the outside of the barrier, except during an early time period when release by the thermo-induced flow through the top of the barrier is contributing. With a hydraulic cage where not all channels in the rock are intersected by the cage (case 1 in Chapter 12), the amount of contaminated water will be 10 times less (cage efficiency 90%) than without a cage. The travel time from the cage to the biosphere is reduced by a factor of two, which means that the travel distance is as effective as half the distance without a cage, i.e. 50 metres. The distance from the bentonite/sand barrier to the cage is set to 50 metres. The total effective travel distance in the geosphere would then be 100 metres. Over this distance the retardation due to sorption and decay will be negligible. The conclusion will then be that the presence of a hydraulic cage in this case results in a 10 times lower release rate to the geosphere.

With a hydraulic cage intersecting all channels (case 2 in Chapter 12) assumed for the Low Flow Through Case, the water velocity in the rock inside the cage will be 10 times lower (cage efficiency 90%) than without a cage. This results in 3 times lower release rate from the bentonite/sand barrier and 10 times longer

residence time in the rock inside the cage. For a long lived nuclide like U-238 the increase in residence time is negligible. The effect of the cage for long lived nuclides will then be a 3 times reduction in release rate to the biosphere. For more short lived and highly sorbing nuclides an additional decrease is expected due to the longer residence time in the rock inside the cage. This would be the case as long as the transport distance between the bentonite/sand barrier and the biosphere is small (100 — 200 m). For larger transport distances the effect of the cage will be less important because the larger transport distance outside the cage and the higher water flow in the rock outside the cage will compensate the reduced release from the bentonite/sand barrier and the longer residence time in the rock inside the cage.

In the High Flow Through Case the nuclide release from the bentonite/sand barrier is dominated by water flowing through the repository. The flow is caused by both the natural gradient and thermal gradient. The thermally induced flow is not influenced by the presence of a hydraulic cage. In the early time period the release from the bentonite/sand barrier is dominated by the thermal flow. During this time period a cage will then not significantly reduce the release from the barrier. After about 10 000 years the thermally induced flow has decreased to the same value as the natural ground water flow. At that time a hydraulic cage will reduce the release rates from the bentonite/sand barrier to about half the value obtained without the cage since the cage will reduce the natural gradient over the repository by a factor of 10. After about 100 000 years the thermal gradient has decayed and the dominating release from the barrier is occurring by the natural ground water flow through the top of the barrier. A hydraulic cage will then for times longer than 100 000 years reduce the release rates from the barrier with at most a factor of 10. It is not foreseen that the change in travel time in the rock inside the cage that might occur with a hydraulic cage present will give an additional effect that is significant. For the High Flow Through Case the reduction in nuclide release rates to the biosphere achieved with a hydraulic cage would then be equal to the above estimated reduction in the release rates from the bentonite/sand barrier.

15.4 RADIONUCLIDE MIGRATION IN BIOSPHERE AND RESULTING DOSE

15.4.1 General Description

In the biosphere analysis, the turnover in the biosphere of radionuclides released from the geosphere was determined /Nordlinder and Bergström, 1989/. The dose to critical groups was calculated for three different cases. In the first case, the exposure to man occurs via the activity in the ground water reaching a well. This water is used as drinking water for man and animal, and also for irrigation of a small garden plot. In the second case, a lake is the primary recipient. Man is exposed to radiation from the activity in the lake by consumption of fish and water and by irrigation of garden plots and farming land. The third case is a combination of the two previous cases with the well as prime recipient but exposure also occurs via the activity from the nuclides reaching the lake.

The ecosystem was chosen to be likewise the one previously used in the analysis of the KBS-3 concept. The area represents a typical landscape in the middle of Sweden with mostly woodlands containing small agricultural areas. The lake has an oligotrophic profile and is assumed to have a volume of

$3.2 \cdot 10^6 \text{ m}^3$ and a mean depth of 8 metres. The residence time in the lake is assumed to be about 3 years.

The well is located in a repository discharge area. The nuclide concentration in the well is dependent on the ratio of nuclide contaminated water to non-nuclide contaminated water that reaches the well. At present it is not clear how this ratio should be estimated. Because of this, two different values of the dilution are assumed. One is the same as was used in KBS-3 /1983/, where it was assumed that the nuclide concentration in the water in the well corresponds to the yearly nuclide release from the far field diluted in $500\,000 \text{ m}^3$ water. Because of the differences in design and depth of the location between a KBS-3 repository and a WPC, the dilution will most probable be less than this in a well near a WPC. The smallest dilution is assumed to correspond to the mixing of the yearly far field release in $2\,000 \text{ m}^3$ of water, see Chapter 13. This volume of water is equal to the estimated volume of water that per year is pumped out from a well (about $6 \text{ m}^3 \cdot \text{d}^{-1}$).

15.4.2 Calculation Model

The compartment model BIOPATH was used to calculate the nuclide transport in the biosphere. In this model the ecosystem is divided into compartments representing the different parts of the system that will be of importance for the dispersion and turn over of radionuclides, see Figure 15-9. The well where the contaminated ground water enters the system is represented by a water reservoir. Water from the well is taken for irrigation of a small garden plot. Nuclides transferred to the garden plot via the irrigation water move through the top soil down to the deeper soil. Some recirculation of nuclides by the ground water to the well will also occur. The water in the lake is simulated by one reservoir and the lake sediments by two, one representing the upper aerated zone and the other the deeper zone which acts as a sink for radionuclides. It is further assumed that the water in the lake is used for irrigation of farming land located in the vicinity of the lake. The nuclides transferred to the farming land migrate through the top soil layer to the deeper soil layer and is transported back to the lake by the ground water. Release of nuclides to the atmosphere from the top soil of the farming land will also occur. The sizes of the reservoirs used in the calculations are given in Table 15-8.

Table 15-8. Reservoir sizes.

Local ground water, (m^3)	$2.5 \cdot 10^5, 2.0 \cdot 10^3$
Local surface soil, (kg)	$1.7 \cdot 10^5$
Local deep soil, (kg)	$1.6 \cdot 10^6$
Lake, (m^3)	$3.2 \cdot 10^6$
Lake surface sediment, (kg)	$4.8 \cdot 10^7$
Regional surface soil, (kg)	$3.9 \cdot 10^7$
Regional deep soil, (kg)	$3.8 \cdot 10^8$
Regional ground water, (m^3)	$9.4 \cdot 10^4$
Regional atmosphere, (m^3)	$3.7 \cdot 10^{14}$

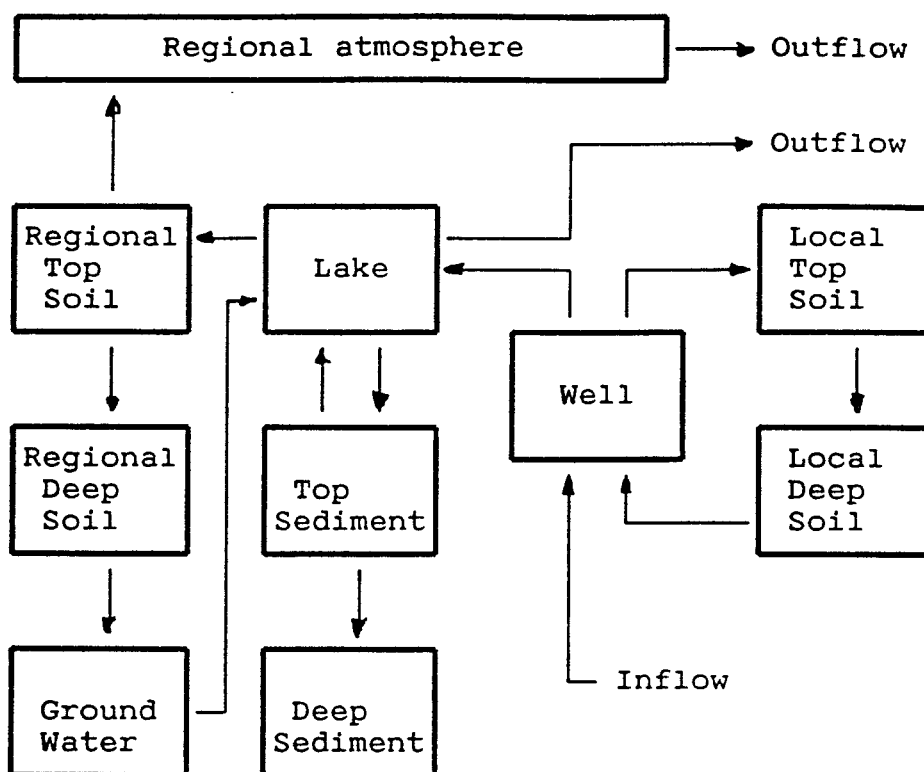

Figure 15-9. Structure of the compartment system.

The exchange of nuclides between the compartments is mathematically expressed in terms of transfer coefficients which either are general or element dependent. These coefficients simulate the physical and chemical processes by which nuclides are dispersed in the biosphere. The general transfer coefficients used in the calculations are given in Table 15-9, and the element dependent for some dose important nuclides in Table 15-10.

Table 15-9. Transfer coefficients independent of element.

Compartments	Transfer coefficient, (a ⁻¹)
well — local top soil	$2.4 \cdot 10^{-4}$, 0.01 ¹⁾
well — lake	2.0, 1.0 ¹⁾
lake — regional top soil	$4.4 \cdot 10^{-3}$
lake — outflow	0.3
top sediment — lake	$1.0 \cdot 10^{-3}$
top sediment — deep sediment	0.03
regional top soil — regional atmosphere	$1.0 \cdot 10^{-5}$
regional atmosphere — global atmosphere	150

¹⁾ values used for the case with dilution in the well of 2 000 m³ per year.

Table 15-10. Element specific transfer coefficients for some dose important nuclides.

Compartments	Transfer coefficient (a^{-1})				
	Se	I	Sn	Pu	Np
Top soil to deep soil	0.3	0.01	0.031	$6.3 \cdot 10^{-5}$	0.031
Deep soil to well or ground water	0.017	$6.0 \cdot 10^{-4}$	$1.8 \cdot 10^{-3}$	$3.5 \cdot 10^{-6}$	$1.8 \cdot 10^{-3}$
Lake water to sediment	0.62	0.038	5.4	9.6	1.2
Ground water to lake	$2.0 \cdot 10^{-3}$	0.02	$2.0 \cdot 10^{-4}$	$4.0 \cdot 10^{-7}$	$2.0 \cdot 10^{-4}$

Man receives radiation doses via different paths of exposure. Internal exposure occurs via inhalation, consumption of food and drinking water and external exposure occurs via radiation from contaminated soil. Internal exposure from food can take place via a number of links in the ecological transport chain. In the BIOPATH model the transfer from compartments to food chains is expressed as a concentration factor or a distribution factor.

In this study the individual doses to three different critical groups were calculated. For all three groups the external exposure pathway assumed is via radiation from contaminated soil, and the internal exposure pathway for inhalation is assumed to be via inhalation of dust from resuspension of the contaminated soil area.

The first critical group which only uses water from the well is also internally exposed to radiation via:

- Drinking water from the well;
- Consumption of meat, milk, and eggs, contaminated via water from the well which is used as drinking water for cattle and poultry;
- Consumption of vegetables grown on the soil area which is contaminated by irrigation with water from the well.

The second critical group which only uses water from the lake, in addition to the external exposure and the internal exposure via inhalation, is also exposed to radiation via:

- Drinking water from the lake;
- Consumption of meat, milk, and eggs, contaminated via water from the lake (drinking water for cattle and poultry) and via cereals and pasturage grown on the contaminated soil area (feed stuff for poultry and cattle);
- Consumption of vegetables and cereals grown on the soil area which is contaminated by irrigation with water from the lake;
- Consumption of fish from the lake.

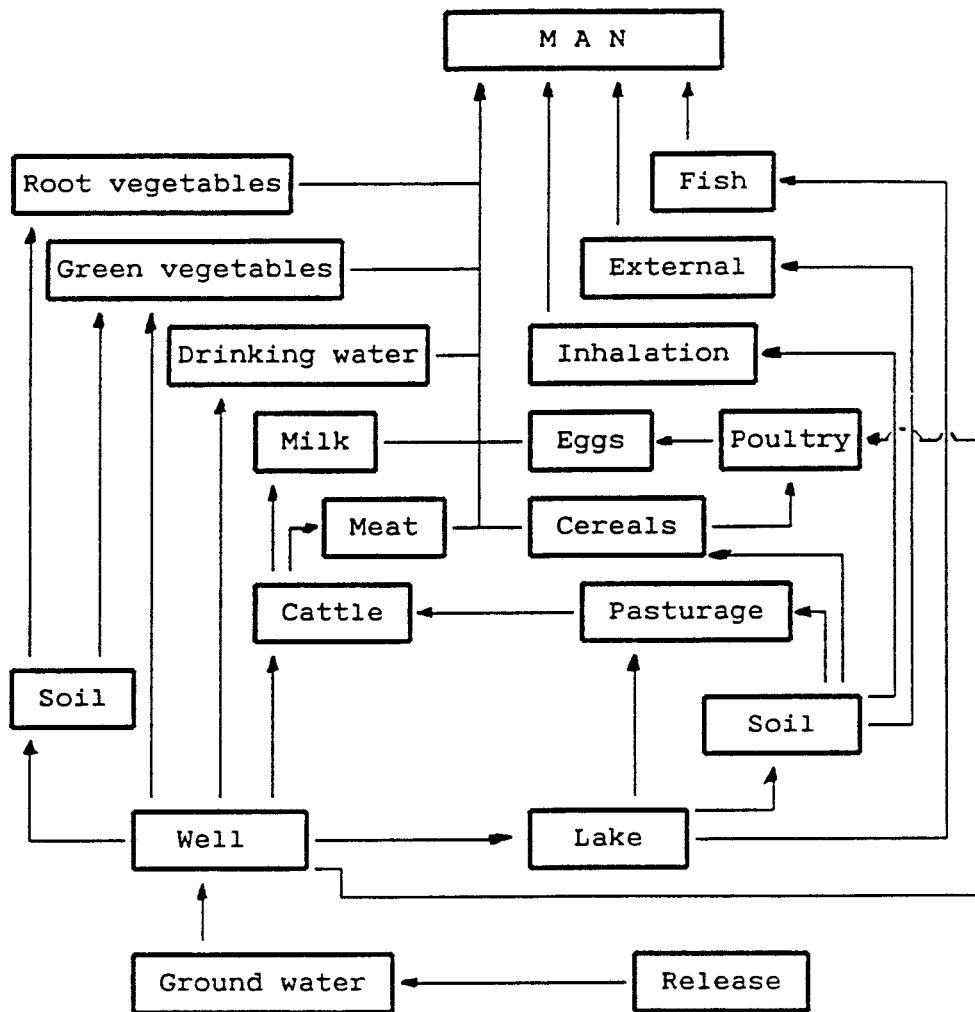

Figure 15-10. Exposure pathways for the critical group in the combined well /lake scenario.

The third critical group uses water from the well as drinking water for man and cattle and consumes food products which are grown on the soil area contaminated with water from the lake. They also consume fish from the lake. A schematic presentation of the exposure pathways for this combined well and lake scenario is given in Figure 15-10.

The consumption data used in the calculations are the same for all three above described scenarios and are given in Table 15-11. The concentration and distribution factors used for the transfer from compartment to food chain are given in Table 15-12 for some dose important nuclides.

In order to transform the intake of activity to radiation dose, a dose conversion factor is used. This factor is dependent on the exposure situation, the decay energy of the nuclide, and the type of radiation and turnover in the body. The dose conversion factors used in the calculations are the sum of ICRP's weighted organ dose equivalent commitments, according to ICRP30 and ICRP48. The factors for some of the dose dominating nuclides are given in Table 15-13.

Table 15-11. Data on consumption per year used in the calculations.

	INDIVIDUALS	CATTLE	POULTRY
Inhalation, (m ³)	9438 ¹⁾		
Drinking water, (m ³)	0.44	33	0.091
Milk, (m ³)	0.19		
Meat, (kg)	55		
Eggs, (pc)	200		
Green vegetables, (kg)	25, 10 ²⁾		
Root vegetables, (kg)	75, 25 ²⁾		
Cereals, (kg)	75		40
Fish, (kg)	30		
Forage, (kg)		5840	
Soil, (kg)		110	

¹⁾ in the well scenario the time to cultivate the plot is limited and the inhalation during that time is assumed to be 96 m³ · a⁻¹.

²⁾ value used for the case with dilution in the well in 2 000 m³ per year.

Table 15-12. Concentration and distribution factors for activity transfer from compartments into food chains.

	Se	I	Sn	Pu	Np
Pasturage to soil ¹⁾	6.5	0.1	0.1	9.0 · 10 ⁻³	0.036
Cereals to soil ²⁾	1.5	0.2	0.36	3.0 · 10 ⁻⁵	4.6 · 10 ⁻⁴
Root vegetab to soil ²⁾	6.5	0.2	0.06	1.0 · 10 ⁻⁴	0.02
Green vegetab. to soil ²⁾	13	0.2	0.046	1.0 · 10 ⁻⁴	2.8 · 10 ⁻³
Fish to lake water ³⁾	2 000	50	3 000	30	10
Milk, (day l ⁻¹)	4.0 · 10 ⁻³	0.013	1.2 · 10 ⁻³	1.0 · 10 ⁻⁷	5.0 · 10 ⁻⁶
Meat, (day · kg ⁻¹)	9.0 · 10 ⁻⁴	0.02	2.5 · 10 ⁻³	2.0 · 10 ⁻⁶	3.0 · 10 ⁻³
Egg, (day · pc ⁻¹)	0.1	0.08	5.0 · 10 ⁻⁵	1.0 · 10 ⁻⁴	1.0 · 10 ⁻⁴

¹⁾ (Bq · kg⁻¹ dry weight)/(Bq · kg⁻¹ dry weight)

²⁾ (Bq · kg⁻¹ fresh weight)/(Bq · kg⁻¹ dry weight)

³⁾ (Bq · kg⁻¹ muscle fresh weight)/(Bq · l⁻¹)

Table 15-13. Dose factors, ($\text{Sv} \cdot \text{Bq}^{-1}$), for intake via inhalation and ingestion for some dose important nuclides.

Nuclide	Inhalation	Ingestion
C-14	$5.7 \cdot 10^{-10}$	$5.7 \cdot 10^{-10}$
Se-79	$2.4 \cdot 10^{-9}$	$2.3 \cdot 10^{-9}$
Sn-126	$2.3 \cdot 10^{-8}$	$4.7 \cdot 10^{-9}$
I-129	$4.7 \cdot 10^{-8}$	$9.8 \cdot 10^{-8}$
Pu-242	$1.3 \cdot 10^{-4}$	$1.1 \cdot 10^{-6}$
Np-237	$1.3 \cdot 10^{-4}$	$1.2 \cdot 10^{-6}$

The dose calculations for C-14 were carried out by a specific activity method due to the special behaviour of carbon in nature. Carbon is one of the major elements in all living organisms, and there is no difference in the behaviour between stable and radioactive carbon. In the well scenario, the dominant exposure pathway is via drinking water. Here it was assumed that 99% of the dose is obtained via drinking water. The annual dose obtained from C-14 was then calculated from the activity of carbon in the water in the well, the annual intake of water from the well and the dose factor for ingestion. In the well/lake scenario the dominant exposure pathway is via consumption of fish. The ratio of stable carbon in fish to stable carbon in water in an oligotrophic lake is $5 \cdot 10^4$. Assuming steady state conditions, this ratio was used to calculate the concentration of radioactive carbon in fish. From the annual intake of fish and the dose factor for ingestion, the annual dose obtained from C-14 in the lake- and in the well/lake scenarios was calculated.

15.4.3 Resulting Doses to Man

Calculated doses to man in a well only scenario and in a combined well/lake scenario from a continuous release of 1 Bq per year from the geosphere are given in Table 15-14. The small dilution in the well was considered for some of the dose important nuclides in the well only scenario. The major exposure pathways in the well scenario is via drinking water. In the combined well/lake scenario the major exposure to radiation from actinides and daughters occurs via drinking water, while consumption of fish and food are the dominating pathways for fission and activation products.

The maximum annual dose from nuclides escaping from a WPC repository in the Low Flow Through Case is given in Table 15-15 together with the maximum release rate from the geosphere. The dose rates from all nuclides in the Pu-242 chain, except Pu-242, were calculated with the actual release rate curves from the geosphere as input to the BIOPATH model. No calculations of the release rate curves from the far field of the remaining nuclides have been made with solubility limited release curves from the near field as input. The maximum release rate from the far field of the solubility limited nuclides Tc-99 and Pd-107 has therefore conservatively been assumed to be equal to the maximum release rate from the near field. The same assumption has been made for the parent and early daughter nuclides in the Pu-240 chain, Np-237 chain, and Pu-239 chain. The maximum release rate of Th-232 is assumed to increase during the far field transport by the same factor as in the case with non-solubility limited release. Th-229 and Pa-231 are conservatively assumed to be in equilibrium with their

parent nuclides. From these estimated maximum release rates from the far field and the dose rates from a release of 1 Bq per year, see Table 15-14, the maximum annual dose from each nuclide has been calculated.

The maximum total dose rate during the first 10⁶ years after canister failure is approximately equal to the sum of the dose rates from the fission and activation products, and at times longer than 10⁶ years approximately equal to the sum of the dose rates from the actinides with daughters. The highest total dose rate is caused by the fission and activation products with a dominating contribution from C-14 in the combined well/lake scenario. With the large dilution of the release reaching the well, this total dose is less than 10 μSv per year. For the well only scenario the maximum total dose will not exceed 1 μSv per year.

Table 15-14. Dose (Sv · a⁻¹) from continuous release of 1 Bq per year from the far field.

Nuclide	Well scenario, dilution in		Well/Lake scenario
	500 000 m ³ · a ⁻¹	2 000 m ³ · a ⁻¹	
C-14	5.0 · 10 ⁻¹⁶	1.2 · 10 ⁻¹³	8.6 · 10 ⁻¹⁴
Ni-59	6.6 · 10 ⁻¹⁷		1.0 · 10 ⁻¹⁶
Se-79	6.8 · 10 ⁻¹⁵	7.0 · 10 ⁻¹³	5.5 · 10 ⁻¹⁴
Zr-93	2.4 · 10 ⁻¹⁵		2.4 · 10 ⁻¹⁵
Nb-94	2.3 · 10 ⁻¹³		1.2 · 10 ⁻¹⁴
Tc-99	3.1 · 10 ⁻¹⁶		4.8 · 10 ⁻¹⁶
Pd-107	4.4 · 10 ⁻¹⁷		6.8 · 10 ⁻¹⁷
Sn-121m	4.5 · 10 ⁻¹⁵		2.8 · 10 ⁻¹⁵
Sn-126	6.0 · 10 ⁻¹⁵	1.1 · 10 ⁻¹²	3.0 · 10 ⁻¹⁴
I-129	2.7 · 10 ⁻¹³	3.7 · 10 ⁻¹¹	4.7 · 10 ⁻¹³
Cs-135	3.2 · 10 ⁻¹⁵		1.3 · 10 ⁻¹³
Pu-242	1.4 · 10 ⁻¹²	2.7 · 10 ⁻¹⁰	1.3 · 10 ⁻¹²
Pu-240	1.2 · 10 ⁻¹²		1.3 · 10 ⁻¹²
Pu-239	1.4 · 10 ⁻¹²		1.4 · 10 ⁻¹²
Np-237	1.2 · 10 ⁻¹²	2.7 · 10 ⁻¹⁰	1.2 · 10 ⁻¹²
U-238	2.7 · 10 ⁻¹³		3.6 · 10 ⁻¹³
U-236	2.9 · 10 ⁻¹³	7.2 · 10 ⁻¹¹	3.8 · 10 ⁻¹³
U-235	2.8 · 10 ⁻¹³		3.7 · 10 ⁻¹³
U-234	3.0 · 10 ⁻¹³		3.9 · 10 ⁻¹³
U-233	3.1 · 10 ⁻¹³		4.1 · 10 ⁻¹³
Th-234	5.8 · 10 ⁻¹⁶		5.9 · 10 ⁻¹⁶
Th-232	1.4 · 10 ⁻¹²		1.5 · 10 ⁻¹²
Th-231	1.0 · 10 ⁻¹⁷		4.7 · 10 ⁻¹⁸
Th-230	2.3 · 10 ⁻¹³		2.5 · 10 ⁻¹³
Th-229	1.7 · 10 ⁻¹²	3.1 · 10 ⁻¹⁰	1.8 · 10 ⁻¹²
Pa-233	1.4 · 10 ⁻¹⁶		1.4 · 10 ⁻¹⁶
Pa-231	2.3 · 10 ⁻¹¹	5.1 · 10 ⁻⁹	2.4 · 10 ⁻¹¹
Ra-226	3.4 · 10 ⁻¹³	7.6 · 10 ⁻¹¹	3.9 · 10 ⁻¹³
Pb-210	1.2 · 10 ⁻¹²	3.0 · 10 ⁻¹⁰	5.1 · 10 ⁻¹²

Table 15-15. Low Flow Through Case results. Maximum release rates from the far field and resulting maximum annual doses. Dilution in the well of 500 000 m³ · a⁻¹.

Nuclide	Max release (Bq · a ⁻¹)	Max dose, (Sv · a ⁻¹)	
		Well scenario	Well/Lake scenario
C-14 ¹⁾	7.2 · 10 ⁷	3.6 · 10 ⁻⁸	6.2 · 10 ⁻⁶
Ni-59 ¹⁾	1.5 · 10 ⁶	9.9 · 10 ⁻¹¹	1.5 · 10 ⁻¹⁰
Se-79 ¹⁾	1.3 · 10 ⁷	8.8 · 10 ⁻⁸	7.2 · 10 ⁻⁷
Zr-93	5.6 · 10 ¹	1.3 · 10 ⁻¹³	1.3 · 10 ⁻¹³
Nb-94 ¹⁾	2.8 · 10 ³	6.4 · 10 ⁻¹⁶	3.4 · 10 ⁻¹⁷
Tc-99	1.8 · 10 ⁵	5.6 · 10 ⁻¹¹	8.6 · 10 ⁻¹¹
Pd-107	5.4 · 10 ²	2.4 · 10 ⁻¹⁴	3.7 · 10 ⁻¹⁴
Sn-121m ¹⁾	<0.44	<2.0 · 10 ⁻¹⁵	<1.2 · 10 ⁻¹⁵
Sn-126 ¹⁾	1.4 · 10 ⁷	8.4 · 10 ⁻⁸	4.2 · 10 ⁻⁷
I-129 ¹⁾	1.8 · 10 ⁶	4.9 · 10 ⁻⁷	8.5 · 10 ⁻⁷
Cs-135 ¹⁾	3.8 · 10 ⁵	1.2 · 10 ⁻⁹	5.0 · 10 ⁻⁸
Total dose, fission and activation products		7.0 · 10⁻⁷	8.3 · 10⁻⁶
Pu-240	15	1.8 · 10 ⁻¹¹	2.0 · 10 ⁻¹¹
U-236	9.6 · 10 ²	2.8 · 10 ⁻¹⁰	3.6 · 10 ⁻¹⁰
Th-232	2.5	3.5 · 10 ⁻¹²	3.8 · 10 ⁻¹²
Np-237	2.2 · 10 ⁵	2.6 · 10 ⁻⁷	2.6 · 10 ⁻⁷
Pa-233	*	3.1 · 10 ⁻¹¹	3.1 · 10 ⁻¹¹
U-233	1.0 · 10 ⁵	3.1 · 10 ⁻⁸	4.1 · 10 ⁻⁸
Th-229	*	1.7 · 10 ⁻⁷	1.8 · 10 ⁻⁷
Pu-242	4.1 · 10 ⁴	5.8 · 10 ⁻⁸	5.8 · 10 ⁻⁸
U-238	1.2 · 10 ²	3.3 · 10 ⁻¹¹	4.4 · 10 ⁻¹¹
Th-234	*	3.2 · 10 ⁻¹³	3.6 · 10 ⁻¹³
U-234	2.1 · 10 ²	6.4 · 10 ⁻¹¹	8.5 · 10 ⁻¹¹
Th-230	1.0 · 10 ²	2.2 · 10 ⁻¹¹	2.3 · 10 ⁻¹¹
Ra-226	3.0 · 10 ³	1.0 · 10 ⁻⁹	1.0 · 10 ⁻⁹
Pb-210	*	3.9 · 10 ⁻⁹	1.5 · 10 ⁻⁹
Pu-239	6.1	8.5 · 10 ⁻¹²	8.5 · 10 ⁻¹²
U-235	1.3 · 10 ²	3.6 · 10 ⁻¹¹	4.8 · 10 ⁻¹¹
Th-231	*	1.3 · 10 ⁻¹⁵	6.1 · 10 ⁻¹⁵
Pa-231	*	3.0 · 10 ⁻⁹	3.1 · 10 ⁻⁹
Total dose, actinides and daughters		5.3 · 10⁻⁷	5.4 · 10⁻⁷

¹⁾ nuclides without or not affected by any solubility limit.

* daughter in equilibrium with parent nuclide in ground water reaching the well.

A smaller dilution of the far field release will increase the dose rates. In Table 15-16 a comparison between dilution in 500 000 m³ per year and in 2 000 m³ per year is made for some of the dose dominating nuclides. The dose rates in the well only scenario for the case with the small dilution have been calculated from the maximum far field release and the annual dose from a continuous release of 1 Bq per year, see Table 15-14. For the combined well/lake scenario the doses are estimated from dose and dominating exposure pathways in the combined well/lake scenario with the large dilution in the well, and from the well only scenario with the small dilution. Consumption of water from the well dominates the dose from the actinides and daughters, Sn-126, and I-129, and the dose rates from these nuclides will therefore be about the same in the combined well/lake scenario as in the well only scenario. The contribution via consumption of fish to the dose from C-14 and Se-79 will result in somewhat higher values for the combined scenario compared to the well only scenario.

With the small dilution of the far field release the maximum total dose will be in the order of 100 μSv per year for both the well only and combined well and lake scenario. The dose rate from actinides and daughters is here of equal magnitude as the dose rate from fission and activation products.

Table 15-16. Low Flow Through Case results. Comparison between large and small dilution of the far field release.

	Maximum dose, (Sv · a ⁻¹), dilution in			
	500 000 m ³ · a ⁻¹		2 000 m ³ · a ⁻¹	
	well	well/lake	well	well/lake
C-14	3.6 · 10 ⁻⁸	6.2 · 10 ⁻⁶	9.0 · 10 ⁻⁶	1.5 · 10 ⁻⁵
Se-79	8.8 · 10 ⁻⁸	7.2 · 10 ⁻⁷	9.1 · 10 ⁻⁶	9.7 · 10 ⁻⁶
Sn-126	8.4 · 10 ⁻⁸	4.2 · 10 ⁻⁷	1.5 · 10 ⁻⁵	1.6 · 10 ⁻⁵
I-129	4.9 · 10 ⁻⁷	8.5 · 10 ⁻⁷	6.7 · 10 ⁻⁵	6.7 · 10 ⁻⁵
Total	7.0 · 10⁻⁷	8.2 · 10⁻⁶	1.0 · 10⁻⁴	1.1 · 10⁻⁴
U-236	2.8 · 10 ⁻¹⁰	2.9 · 10 ⁻¹⁰	6.9 · 10 ⁻⁸	6.9 · 10 ⁻⁸
Np-237	2.6 · 10 ⁻⁷	2.6 · 10 ⁻⁷	5.9 · 10 ⁻⁵	5.9 · 10 ⁻⁵
Th-229	1.7 · 10 ⁻⁷	1.8 · 10 ⁻⁷	3.1 · 10 ⁻⁵	3.1 · 10 ⁻⁵
Pu-242	5.8 · 10 ⁻⁸	5.8 · 10 ⁻⁸	1.1 · 10 ⁻⁵	1.1 · 10 ⁻⁵
Ra-226	1.0 · 10 ⁻⁹	1.0 · 10 ⁻⁹	2.3 · 10 ⁻⁷	2.3 · 10 ⁻⁷
Pb-210	3.9 · 10 ⁻⁹	1.5 · 10 ⁻⁸	9.0 · 10 ⁻⁷	9.0 · 10 ⁻⁷
Pa-231	3.0 · 10 ⁻⁹	3.1 · 10 ⁻⁹	6.6 · 10 ⁻⁷	6.6 · 10 ⁻⁷
Total	5.0 · 10⁻⁷	5.2 · 10⁻⁷	1.0 · 10⁻⁴	1.0 · 10⁻⁴

The increase in dose rates from actinides and daughters are higher than that from fission and activation products. The explanation for this is from the differences in assumptions made between the cases with large and small dilution of the far field release. It was assumed that the volume of water which could be taken from the well each year for irrigation of the garden plot to be smaller when the dilution is in 2 000 m³ per year compared to 500 000 m³ per year because of the lower inflow of water to the well in the former case. As a consequence of this, the amount of vegetables grown on the plot and the annual consumption of these vegetables are assumed to be lower. These differences in consumption data have a minor effect on the dose rates from actinides and daughters because almost all exposure to man from this nuclide radiation occurs via drinking water from the well. The most important factors for the dose rates from actinides and daughters are then the nuclide concentration in the well and the annual consumption of water from the well. For many of the fission and activation products, however, exposure to man via other pathways such as food is as important as the exposure via drinking water. In addition to the concentration in the well and the annual consumption of water, the amount of irrigation and consumption of the grown food products on the irrigated plot are of importance for the dose rates from the fission and activation products.

For the High Flow Through Case no calculations with the BIOPATH model have been performed. Dose rates have been estimated by using the High Flow Through to Low Flow Through ratio in maximum release rate from the bentonite/sand barrier and the dose rates calculated for the Low Flow Through Case. The results are presented in Table 15-17 for the combined well/lake scenario with dilution for both 500 000 m³ per year and 2 000 m³ per year.

Table 15-17. High Flow Through Case results. Maximum annual dose, (Sv · a⁻¹), for the combined well/lake case.

Nuclide	Maximum dose, (Sv · a ⁻¹), dilution in	
	500 000 m ³ · a ⁻¹	2 000 m ³ · a ⁻¹
C-14	2.0 · 10 ⁻⁴	4.8 · 10 ⁻⁴
Se-79	4.3 · 10 ⁻⁶	5.8 · 10 ⁻⁵
Sn126	2.9 · 10 ⁻⁶	1.1 · 10 ⁻⁴
I-129	1.6 · 10 ⁻⁵	1.3 · 10 ⁻³
Total	2.2 · 10⁻⁴	2.0 · 10⁻³
Np-237	1.6 · 10 ⁻⁶	3.5 · 10 ⁻⁴
Th-229	9.0 · 10 ⁻⁷	1.9 · 10 ⁻⁴
Pu-242	6.4 · 10 ⁻⁷	1.2 · 10 ⁻⁴
Total	3.1 · 10⁻⁶	6.6 · 10⁻⁴

With the large dilution in the well the maximum total dose from the fission and activation products is approximately $200 \mu\text{Sv} \cdot \text{a}^{-1}$. The actinides and daughters which enter the biosphere at a later time, and have a longer residence time in the biosphere, will cause a maximum total dose of about $3 \mu\text{Sv} \cdot \text{a}^{-1}$. A small dilution of the nuclide release reaching the well will increase the total dose from fission and activation products to approximately $2 \text{mSv} \cdot \text{a}^{-1}$, and the total dose from actinides and daughters to about $700 \mu\text{Sv} \cdot \text{a}^{-1}$. Compared to the results for the Low Flow Through Case the dose rate from fission and activation products is 20 times higher and from actinides and daughters 6 to 7 times higher.

What is said above about doses to man is valid for one WPC only. If several WPCs are located at one site, it is most probable that the nuclide release from each of them accumulate, so that the combined effect is a higher dose rate than from one WPC alone. Following a simple rule of thumb in hydrology, the combined effect would be an increase in the dose rate by a factor that is equal to the square root of the ratio between the diameter of the area for all seven WPCs to the diameter of one WPC. With reference to the measures given in Chapter 2 this would give an increase of $\sqrt{1000/230}$ which is about two times the value of one WPC for seven WPCs located at one site and as close together as possible.

15.5 VARIATION CALCULATIONS

15.5.1 Effect of Changing Parameters in Near Field

Lowering the bentonite/sand barrier thickness from 5 metres to 2.5 metres will increase the release rate from the barrier mainly of radionuclides that have a relatively short half life. For the Low Flow Through Case the increase has been estimated to be less than a factor of 5 for all dose dominating nuclides /Lindgren and Skagius, 1989/. The increase in total annual dose will then also be less than a factor of 5.

In the High Flow Through Case the water flow through a 2.5 metre thick barrier should be twice as high as the flow through a 5 metre thick barrier. The nuclide release rates from the barrier and resulting dose rates will then increase with about a factor of 2.

The effect of a higher radiolytic fuel oxidation rate has been determined for the Low Flow Through Case. A higher radiolytic fuel oxidation rate will not change the release rate of solubility limited nuclides. Among the non-solubility limited nuclides that dominate the release from the near field, the short lived non-sorbing C-14 will be most affected by a change in the fuel oxidation rate. A 5 times higher value results in about 2 times higher maximum release rate of C-14 from the near field /Lindgren and Skagius, 1989/. Consequently, the maximum total dose to man will increase by at most a factor of 2 in the Low Flow Through Case if the radiolytic fuel oxidation rate is 5 times higher than the assumed value.

The importance of the natural gradient induced water flow rate in the rock just outside the bentonite/sand barrier on the release from the barrier has also been determined for the Low Flow Through Case. A 10 times higher flow rate will increase the diffusive release rates approximately 3 times. The reason is that the resistance to diffusion from the outside of the barrier to the slowly moving water in the rock is inversely proportional to the square root of the velocity of the water passing the outside of the barrier. At times longer than about 5 000 years after canister breakthrough, the release rates from the barrier are determined by the diffusion resistance. A 10 times higher flow rate in the rock outside the barrier, $3 \cdot 10^{-3}$ instead of $3 \cdot 10^{-4} \text{m}^3 \cdot \text{m}^{-2} \cdot \text{a}^{-1}$, will in this case result in about

3 times higher release rates from the near field. At times up to 5 000 years after canister breakthrough the increase in release rates caused by a 10 times higher water flow rate will be less than a factor of 3.

15.5.2 Effect of Changing Parameters in Far Field

The effect of the properties of the water conducting channels in the geosphere on the release to the biosphere has been studied /Moreno et al., 1989/. Concerning the channel aperture it was concluded that there will be no difference between small and large channels for residence times in the geosphere longer than a few tens of years.

Both the width and length of a channel are important entities because they determine the wetted fracture surface, i.e. the surface in contact with water through which the nuclides diffuse into the rock matrix and sorb. A larger fracture surface available for sorption, larger than what has been assumed in the base case (width = 1 m, length = 100 m), will increase the retardation of sorbing radionuclides in the geosphere. If the transport distance in the geosphere is 400 m instead of 100 m the maximum release rate to the biosphere of the dose important and highly sorbing Np-237 will decrease with a factor of about 2 /Moreno et al., 1989/. The radionuclides that are most important to the total annual dose are, however, some of the non- or slightly sorbing fission and activation products. A longer transport distance in the geosphere will be of minor importance for these nuclides. As an example, the effect of a 4 times longer transport distance on the maximum release rate to the biosphere of I-129 is insignificant.

Another effect of a longer transport distance, important also for non-sorbing nuclides, is the increased possibility of mixing between channels. If the channels intersect many times, the identity of the channels is lost. The fast channels will in that case not dominate the nuclide transport and the maximum release rate of short lived nuclides will be lower. For a nuclide with a half life on the order of 10^5 years, frequent mixing between the channels will reduce the maximum release rate to the biosphere about 2 times compared to no mixing between the channels /Moreno et al., 1989/.

15.6 CONCLUSIONS

In summary it could be concluded that the combined well/lake scenario for the biosphere transport will give the highest dose to man. With the conditions in the near field assumed in the Low Flow Through Case, the bentonite/sand barrier will act as a diffusion barrier, and the dose to man is calculated to be in the range of 10 — 100 μ Sv per year with a dilution of the far field release in 500 000 — 2 000 m^3 per year. For the High Flow Through Case with water flow through the bentonite/sand barrier the dose to man will be 200 — 2 000 μ Sv per year for the above given range in dilution of the far field release. For the well only scenario the range is 1 — 100 μ Sv per year in the Low Flow Through Case. The values are for one WPC. If seven WPCs are located at one site, as close together as possible, the combined effect is likely to be a dose rate to man on the order of two times the dose rate for one WPC.

With water flowing in channels in the geosphere, the far field will be less important as a barrier to escaping radionuclides. The main factors determining the

resulting dose to man are those important to the near field release, and the dilution of the annual release from the far field reaching a drilled well.

The release rates from the near field of the radionuclides which determine the maximum dose rate level, are mainly dependent on the hydraulic properties of the bentonite/sand barrier. A hydraulic conductivity expected to be representative of a 10/90 bentonite/sand mixture ($10^{-10} \text{ m s}^{-1}$) will result in a considerable water flow through the repository. The part of the flow that is thermally induced is not affected by the presence of a hydraulic cage. Only a lower hydraulic conductivity in the bentonite/sand barrier will reduce the thermally-induced flow and consequently also reduce the release rates of dose dominating fission and activation products. A 10 times lower hydraulic conductivity will result in 10 times lower release rates. A prolonged service life of the canisters would also diminish the importance of the thermally induced water flow through the repository since this flow is decreasing with time.

The natural gradient driven water flow through the repository is mainly important to the release of actinides and daughters from the near field. Both a lower hydraulic conductivity in the bentonite/sand barrier and a well functioning hydraulic cage will reduce this water flow through the repository and, consequently also the release rates from the near field.

Solubility limits and sorption in the near field barriers are also important to the release from the bentonite/sand barrier. Data used in the calculations are representative of temperatures around 20°C . At higher temperatures, $100\text{--}150^\circ\text{C}$, the sorption capability will probably be higher than the values used. Higher sorption in the barriers will mainly reduce the release rates of those nuclides that have such short half lives that they do not reach steady state, e.g. some of the dose dominating fission and activation products. Radionuclide solubilities might increase or decrease with increased temperature. For nuclides with long half lives, the release rate at steady state conditions is directly proportional to the solubility of the nuclide.

As can be seen from the previous presented calculation results, the dilution of the far field release reaching a drilled well is another factor of importance to the dose exposure from radionuclides escaping from the repository. An almost linear dependence between dilution in the well and dose exposure from dominating actinides and daughters exists because the dominating exposure pathway for these nuclides is via drinking water from the well. The dose rates from dominating fission and activation products are in general less dependent on the dilution.

In summary it could be concluded that the main factors important to the annual dose to man from radionuclides escaping from the repository are:

- Flow rates through and around the repository;
- Sorption data and solubilities at temperatures up to $100\text{--}150^\circ\text{C}$;
- Dilution of the contaminants in the well.

The far field has been found to be of minor importance as a barrier to the nuclides. Larger channel widths and/or longer transport distances to the biosphere than assumed in the calculations, as well as some mixing between the channels would, however, mean that the barrier properties of the geosphere are better than what has been shown in this study.

16 COST ANALYSIS

This chapter presents the cost analysis on the Swedish back-end system when the final repository for high level waste is designed in accordance with the WPC concept. Comparison is made with the PLAN report /SKB PLAN 86, 1986/ which is based on the KBS-3 concept for final disposal. Also cost sensitivity analyses are presented, which consider the most important parameters affecting the costs such as size of repository, width of bentonite/sand barrier and quality of bentonite and sand.

16.1 GENERAL

The cost study conducted is based on the WPC layout which has a storage capacity of 1 500 tonnes of U, see Appendix 3. A WPC with the same measures is today considered to have a capacity of 1 100 tonnes of U. The calculations have, however, not been done again. Only the extra costs for the additional WPCs have been estimated. In order to rely on the accurate work done in the cost study the presentation below is based on the results of this study on WPC 1500.

Costs have been estimated in the same way as is annually done in the PLAN studies and the same cost basis has been used. Among other things this means that all costs are presented in the cost level of January 1986 and comprises future costs from 1987 and onwards. Only WPC specific cost items have been calculated and in all cases where the costs are the same for WPC and KBS-3 the costs of /SKB PLAN 86, 1986/ have been used.

The Swedish back-end system is schematically presented in Figure 16-1. The final repository for high level waste, called SFL-2, is the only part that is totally changed in design. In addition the encapsulation station, BS, is adjusted for operation of the different canister filling and sealing process, and the repository SFL-5 is made smaller. Other parts of the back-end system are the same as for KBS-3 and the differences in costs are due to the differences in time of operation.

16.2 WASTE QUANTITIES

The quantities of different types of waste are considered to be the same as in PLAN 86. Some minor decreases of operational waste from CLAB and the encapsulation, BS, are expected as a consequence of the shorter time of operation of the facilities, but the change is negligible in comparison with the total quantities.

The quantities are listed in Table 16-1. The volumes are based on an operation of all 12 reactors to the end of the year 2010. The total amount of spent fuel corresponds to about 7600 tonnes of U.

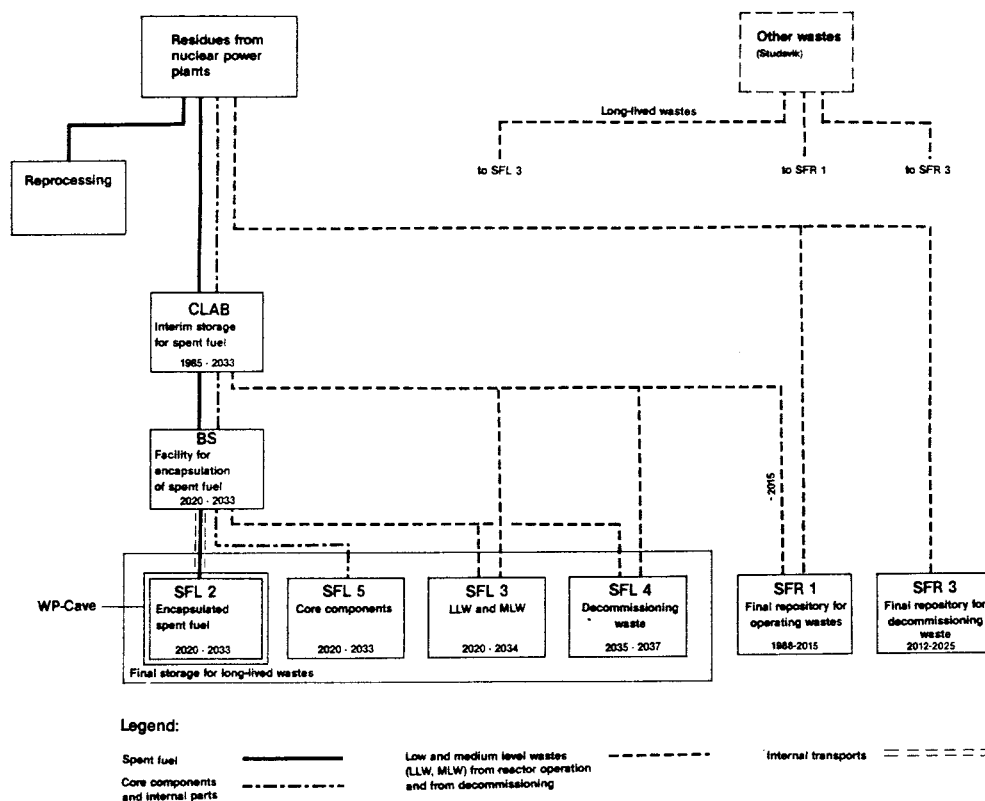

Figure 16-1. Schematic handling chain for back-end system.

Table 16-1. Quantities of nuclear waste in the Swedish system when assuming a WPC repository.

Type of waste	Volume in repository m ³	Repository
Spent fuel in 2800 canisters	20 000	SFL 2
Long-lived waste to SFL 3	11 000	SFL 3
Low-level waste to SFL 4	10 000	SFL 4
Core components	17 000	SFL 5
Low- and intermediate level waste	89 000	SFR 1
Decomm.waste from NPP	104 000	SFR 3

Total volume in the final repositories is 251 000 m³
compared to 246 000 m³ for KBS-3 /SKB PLAN 86, 1986/.

The spent fuel is encapsulated in steel canisters, see presentation of design in Section 7.2. One canister has the same capacity as one CLAB canister, e.g., 16 BWR assemblies or 5 PWR assemblies. One difference between the WPC and the KBS-3 concepts is that the fuel boxes (BWR) are considered to be encapsulated together with the fuel in the WPC canisters. This will reduce the number of moulds to SFL-5.

16.3 TIME SCHEDULE

The same assumptions are applied as in PLAN 86 concerning time for start of disposal and capacity of encapsulation. Thus disposal is planned to start at year 2020 with a capacity of one canister per day, i.e., 210 per year. The latter leads to a doubling of the capacity in tonnes of U as each WPC canister contains two times the amount of fuel as one KBS-3 canister.

The time schedule, as seen in Figure 16-2, presents two periods of operation for SFL-2. The first (14 years) is the disposal period and the second (about 100 years) the ventilation and supervision period.

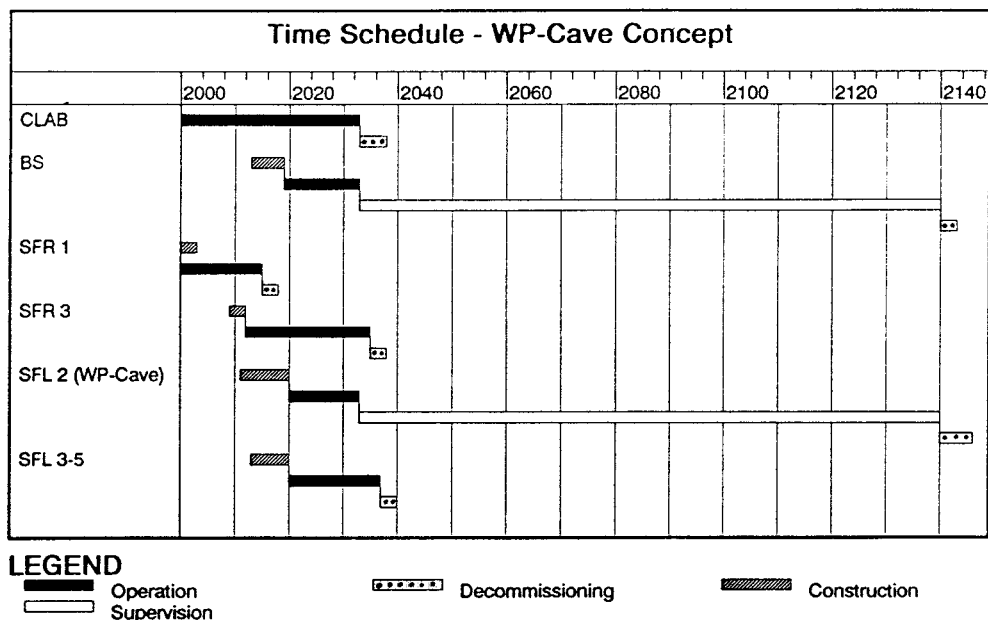

Figure 16-2. Time schedule of back-end operations.

16.4 FACILITIES AND SYSTEMS

The parts of the back-end system that are not considered to be dependent on choice of concept for final repository are:

- SKB administration
- R&D
- Decommissioning of NPP
- SFR 1—3
- Reprocessing

For CLAB the time of operation is shortened with 14 years due to the shorter encapsulation period. The crew is somewhat increased during the shorter period in order to manage the higher handling capacity.

The operational time of the transportation system will as well be shortened with 14 years. In order to manage a double transportation capacity of Sigyn an increased number of transportation casks are required.

In the encapsulation station, BS, only those systems and parts of the building which are involved in the handling of the canisters are affected. Major changes compared to PLAN 86 is the change from a lead filled canister to a canister with inert gas. The change will mean that furnaces, casting equipment, cooling chambers, etc are excluded and systems for heat treating of steel canisters and filling of inert gas added. These changes also result in a reduction of the building volume.

The operation of BS is changed with respect to number of personnel and consumables. The most cost affecting consumables are canister material and lead. When encapsulation is completed only certain parts of BS is maintained in operational condition, such as equipment for retrieving of canisters, e g, lifts, lifting equipment, and water pools. Other systems are dismantled. About 15 years after completed disposal the major parts of this equipment is also taken out of service. Remaining is only the lifts for personal transportation underground. After sealing is completed, surface installations and buildings are dismantled. The crew of BS during the first 14 years is assumed to be about 60 people and during the long term cooling period about 3 people.

Surface facilities of SFL will be larger due to the larger extent of underground work for WPC. At the peak about 2 300 tonnes of bentonite/sand mixture shall be handled per day, which is about 5 to 8 times more than considered in PLAN 86. The hoisting of rock increases 4 to 5 times compared to the capacity of PLAN 86. The larger material handling means that the storing of bentonite and sand as well as the dumping of hoisted rock require a larger spot on the surface. The facilities for the personnel will increase as the underground labour force is increased from about 100 people to about 220 people. The surface operation crew comprises during the first 14 years about 100 people and during the long term control period about 5 people.

The SFL-2 plant is totally different for the WPC design. The basis for the cost estimate is a farm of five caves, WPC-1500, located in connection with an underground receiving and service area, see the general layout in Figure 16-3. The central area is in connection with the surface via three shafts for rock hoisting, canister transportation, and personnel transports. These shafts are the same as those included in the layout of KBS-3. Five additional shafts, one for each cave, are required for ventilation and cooling of the repository. These shafts can also serve as extra escape ways.

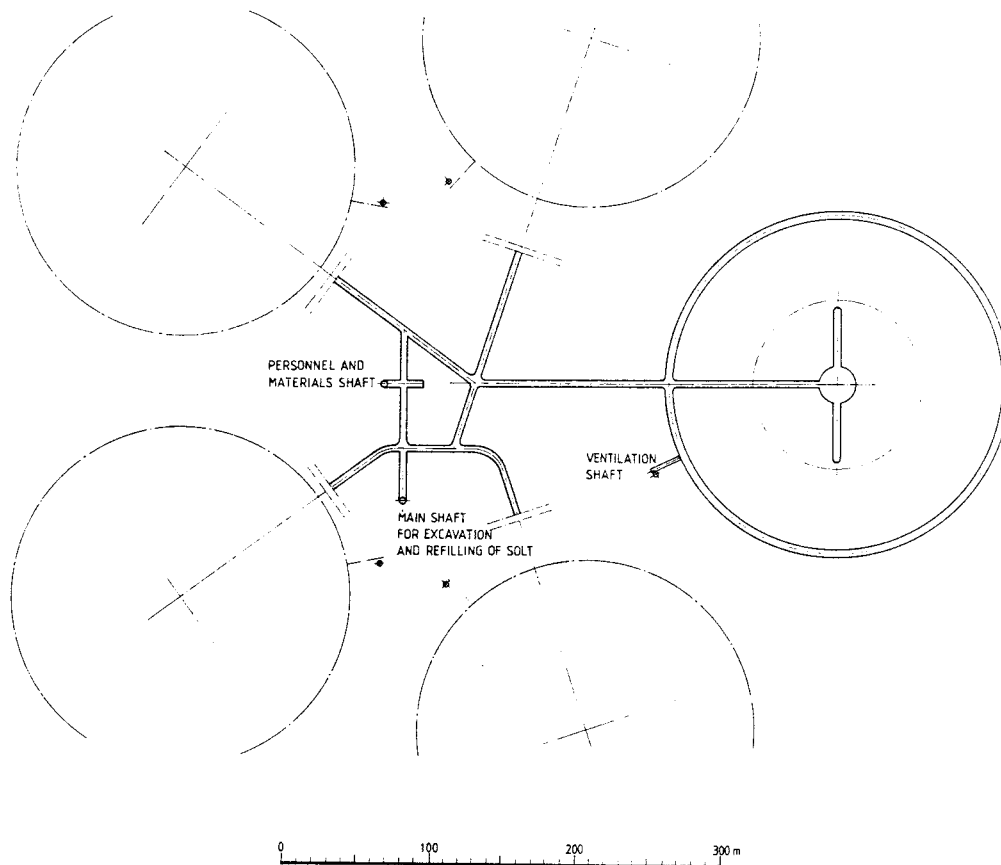

Figure 16-3. General layout in the horizontal plane of a WPC farm.

The exact location of each cave is dependent on site characteristics. From the cost estimate point of view the assumption is made that the repositories are located in the corners of a polygon around the central shafts, with a distance of about 100 m between the hydraulic cages. The top of the bentonite/sand barrier is located at 200 m depth. From the central shafts, on each level, a system of drifts are excavated for transporting of rock and back-fill materials as well as for transporting of canisters.

In total the SFL-2 part comprises excavation of 4 400 000 m³ of rock, of which 2 700 000 m³ is the total volume for the five bentonite/sand barriers. The construction period from initial start up to start of disposal in the first of the five caves is estimated to be 10 years. Thereafter new caves are constructed in sequences so that a new cave can be put into operation every 2.5 years.

The operational period of SFL-2 is 14 years for the active period and then a little over 100 years for the supervision and monitoring period. During the active period 4 people are required for disposal of the canisters. All other personnel are included in the figure for the surface operation.

The additional repositories SFL-3-5 are from a cost estimate point considered to be of the same size as in PLAN 86. The operational period, however, will be 14 years shorter. The crew is estimated to be 20 people.

16.5 COSTS

The cost calculations have in all respects been conducted in the same way as in PLAN 86, for example, the estimated percentage additions for miscellaneous and contingencies, etc are the same. For details on cost calculation methods see the reference document.

By adapting the same principles of cost calculations it is possible to compare the outcome of costs for WPC with the costs for KBS-3 and thereby indicate how the WPC concept compares to the established KBS-3 concept. The summary of costs for both WPC and KBS-3 are shown in Table 16-2. The presentation has the same layout as the presentation in PLAN 86.

The result is that the costs for the WPC repository (with the assumed capacity of 1 500 tonnes of U per WPC) is calculated to be about MSEK 9 300 higher (1986 year cost figures) than for the KBS-3, which corresponds to about 24% of the total costs or 38% of the costs for Transport, CLAB, and Final repository only. The explanation to the cost difference is the increase for SFL-2 with about MSEK 13 800. Decreases are estimated for BS with about MSEK 2 800 and for CLAB with about MSEK 1 400. Transportation represents only a minor decrease in costs.

The increase in costs for SFL-2 is mainly caused by investments in the caves, including sealing. Investment, reinvestment, and sealing stand for about MSEK 17 900 in the WPC calculation, while the corresponding costs categories summarize to MSEK 4 800 for KBS-3. The largest part, about 60% of the investment in five caves, is the cost for construction of the bentonite/sand barrier around the repositories. The possibilities, as discussed later, to improve the cost situation for the WPC lie in the possibilities of reducing the barrier volumes and introducing cheaper bentonite and ballast qualities, see Section 16.7. But the requirement on peak temperature, see Chapter 4 and Section 16.6, results in an additional requirement of two caves, which substantially increases the costs.

The lower costs of BS is mainly caused by lower costs for the canisters. The canisters are fabricated in a cheaper material and the number of canisters are halved. The lead casting process is excluded. In total the production costs due to the change of canister is estimated to represent about MSEK 1 900 of the total difference for BS of about MSEK 2 800.

The reduction in costs for CLAB is totally due to the shorter time of operation.

When estimating the fee on nuclear power production the present value method is used. At discounting, a discounting rate of 2.0 and 2.5% is presently considered appropriate by the National Board for Spent Fuel, SKN. A comparison of the present values (at 2.0%) for the WPC and the KBS-3 calculations shows a difference of about 27%. This is higher than the difference in absolute costs, as the heavy investments for WPC tend to come earlier in time.

Table 16-2. Comparison of total future cost of the Swedish back-end system including five WPC 1500 or one KBS-3. Costs (MSEK) from 1987 in the price level of January 1986.

Object	Cost category	Costs	WPC	Costs	KBS	Cost difference + denotes higher for WPC
SKB-adm						
R&D	Operation	<u>3 158</u>	<u>3 158</u>	<u>3 158</u>	<u>3 158</u>	0
Transport	Investment	56		56		
	Reinvestment	416		440		
	Operation	<u>844</u>	<u>1 316</u>	<u>1 013</u>	<u>1 509</u>	-193
Decomm. of NPP	Operation	<u>7 563</u>	<u>7 563</u>	<u>7 563</u>	<u>7 563</u>	0
CLAB	Investment	621		621		
	Reinvestment	365		594		
	Operation	3 742		4 889		
	Decomm.	<u>228</u>	<u>4 956</u>	<u>228</u>	<u>6 331</u>	-1 375
Final repository						
Common facilities	Investment	2 303		1 876		
	Reinvestment	136		116		
	Operation	924		1 407		
	Decomm.	<u>162</u>	<u>3 525</u>	<u>132</u>	<u>3 531</u>	-6
Encapsula- tion station	Investment	2 018		2 310		
	Reinvestment	46		80		
	Operation	1 767		4 241		
	Decomm.	<u>207</u>	<u>4 038</u>	<u>236</u>	<u>6 866</u>	-2 828
Repository for spent fuel SFL 2	Investment	17 005		2 614		
	Reinvestment	515		28		
	Operation	845		407		
	Sealing	393		2 136		
	Decomm.	<u>250</u>	<u>19 008</u>	<u>30</u>	<u>5 216</u>	+ 13 792
Repository for other high- level waste SFL 3-5	Investment					
	Reinvestment					
	Operation	<u>1 336</u>	<u>1 336</u>	<u>1 395</u>	<u>1 395</u>	-59
	Sealing					
	Decomm.					
Final reposi- tory for opera- tional and NPP decomm. waste						
SFR 1-3		<u>1 143</u>	<u>1 143</u>	<u>1 143</u>	<u>1 143</u>	0
Reprocessing		<u>2 614</u>	<u>2 614</u>	<u>2 614</u>	<u>2 614</u>	0
TOTAL			48 657		39 326	+ 9 331

16.6 WPC 1100

The limitation of the peak temperature on the canister's surface to 150°C results, as discussed in Chapter 4, in an addition of two WPCs in the Swedish system. The effect on the cost estimate is that the additional costs for two extra caves are required. All other costs are maintained the same. The additional costs then for the Swedish program is estimated to be about 2 x MSEK 3 500 = MSEK 7 000, which adds up to MSEK 55 700 for the total future costs. When comparing this figure with the costs for the Swedish system assuming the KBS-3 concept the difference is 42%.

16.7 VARIATION OF COSTS AFFECTING PARAMETERS

Some measures that are technically feasible would, when applied, decrease the costs substantially. These are:

- Size of WPC
- Width of bentonite/sand barrier
- Bentonite quality
- Sand quality

16.7.1 Size of WPC

The detailed costs analysis was made without knowledge of the impact of the temperature and based only on the criterion that the temperature in the bentonite/sand barrier would not be higher than 80°C. From this criterion a larger cave was designed with a capacity of half the Swedish program. This size was denoted WPC 3750. The scale up was made by increasing the length of the canister channels so each channel received room for five canisters. In order to meet the 80°C criterion in the bentonite/sand barrier the buffer rock zone between the outer ventilation shafts and the barrier was increased. Overall the horizontal diameter of the bentonite/sand barrier was increased to 210 m, see Table 16-3 and Appendix 3. The number of canister channel levels is increased about 50% in order to reach the capacity demand of 1 400 canisters. In total the bentonite/sand barrier of WPC 3750 is 100 m higher than the WPC 1500. The increase in dimensions of the hydraulic cage is only the result of the increase in the dimensions of the bentonite/sand barrier.

Table 16-3. Dimensions of WPC 1500 and WPC 3750.

		WPC 1500	WPC 3750
Bentonite/sand barrier			
Outer diameter	m	130	210
Height	m	300	400
Hydraulic cage			
Diameter	m	230	310
Height	m	450	625

The result of the cost analysis is seen in Table 16-4, which covers the surface facilities, encapsulation station, and underground repository for canisters (SFL-2). The reduction in costs is totally dependent on the change in design underground. When considering only costs for SFL-2 the reduction is about 20%.

If the temperature criterion of maximum 150°C on the canister's surface is applied, a similar discussion on measures to be taken should be carried out as was made for the size WPC 1500 in Chapter 4. Without any deeper analysis, a fair estimate is that a proportional decrease in the capacity of WPC 3750 must be made. This would mean that three caves with a size of WPC 3750 would be required for the Swedish program instead of two as assumed for the figures in Table 16-4. A very rough estimate of the cost increase due to this can be made by considering the total costs for SFL. Only a small part of those costs are costs for the central shafts and service area. The major portion of the costs are for the two caves. This implies that the additional costs for one extra WPC 3750 would be in the range of MSEK 7 000—7 500. This means that the cost figure for a larger size in Table 16-4 increases from MSEK 15 241 to about MSEK 22 000—22 700.

**Table 16-4. Cost comparison between two sizes of WP-Cave:
WPC 1500 and WPC 3750.
Costs for 5 m wide bentonite/sand barrier.
Price level of January 1986. MSEK.**

Object	Five WPC 1500	Two WPC 3750	Difference
SFL-BS Surface facilities GA	3 525	3 542	+17
Encapsulation station BS	4 038	4 038	0
Repository SFL 2	19 008	15 241	-3 767
Total difference			-3 750

16.7.2 Width of Bentonite/sand Barrier

The width of the barrier was initially assumed to be 5 m, since this width was known to provide sufficient space for excavation and back-filling. Since a large portion of the total costs is related to the bentonite/sand barrier, it is of importance to decrease the width, if this could be possible from a nuclide release point of view. The smallest width at which the same methods for excavation and back-filling can be used, although with smaller equipment, is 2.3—2.5 m. A further decrease to 1.5 m is possible from a construction point of view, but another excavation method would have to be applied. One exception to the decrease in width is the barrier in the cones. Since the cones have an inclination, the barrier cannot be narrower than 3 m in this area.

The result of the cost analysis is presented in Table 16-5. The difference in the SFL-2 part is about 30% for both WPC 1500 and WPC 3750.

The results concerning a 1.5 m wide barrier indicate that the optimum width from a cost point of view might be somewhat larger. The low productive method

increases the unit costs somewhat more than what is compensated by the reduction in volumes.

Table 16-5. Cost comparison between two widths of the bentonite/sand barrier. Costs are given in price level of January 1986. MSEK.

	WPC 1500		WPC 3750	
Barrier width m	5	2.5	5	2.5
Repository SFL 2	<u>19 000</u>	<u>13 400</u>	<u>15 200</u>	<u>10 200</u>
Difference		-5 600		-5 000

16.7.3 Bentonite and Sand Qualities

The prime qualities considered in the Swedish program are a bentonite of a naturally sodium-rich quality from Wyoming and sand with a quartz-rich marine content recovered at the island of Bornholm in the Baltic Sea.

A less expensive bentonite alternative is Italian bentonite which is used in fairly large quantities in Swedish iron ore pellets. This bentonite contains a higher portion of calcium and a lower portion of sodium than the Wyoming bentonite. In the iron ore pellets industry this is compensated by activation with the help of sodium carbonate.

The bentonite is mined and dried at the deposit. Sodium carbonate is added. The activation takes place during the ship transport from Italy to Sweden. In Sweden the bentonite is ground to the proper size prior to its use in the iron ore pellets. This handling scheme is not unique for Sweden. It should be noted that an Italian bentonite quality was used in the SFR facility.

Based on the same handling as used by the iron ore industry the cost for Italian bentonite, ground in a plant at the site of the final repository, has been calculated. The difference in cost per tonne of material on the stockpile at the site is about SEK 400 or about 40% compared with the Wyoming quality.

A less expensive alternative for supplying sand is to crush and grind the excavated material from the barrier. The costs have been estimated for treatment in a conventional ballast producing plant. The result is a decrease per tonne of SEK 250 which corresponds to about 90% of costs of the Bornholm sand at the SFL site. One important part of the saving is that the hoisted rock is available at the crushing plant while the Bornholm sand would have to be transported to the site.

The cost of the back-fill material will affect both the cost for the SFL-2 repository and the cost for the SFL-3-5 repositories. The impact of the choice of different bentonite and sand qualities for different widths of the barrier is presented in Table 16-6. One thing of interest to note is that the choice of crushed hoisted rock instead of Bornholm sand gives a larger reduction than a switch from Wyoming bentonite to Italian bentonite.

Table 16-6. Comparison of costs for different choices of bentonite and sand qualities. Costs are given in the cost level of January 1986. MSEK.

WB = Wyoming bentonite
 IB = Italian bentonite
 BQ = Bornholm quartz sand
 CR = Crushed rock

Five WPC 1500

Barrier width	5			2.5		
	WB	WB	IB	WB	WB	IB
Bentonite	WB	WB	IB	WB	WB	IB
Sand	BQ	CR	CR	BQ	CR	CR
Repository SFL 2	19 000	15 900	14 500	13 400	11 700	11 000
Difference	0	-3 100	-4 500	-5 600	-7 300	-8 000

Two WPC 3750

Barrier width	5			2.5		
	WB	WB	IB	WB	WB	IB
Bentonite	WB	WB	IB	WB	WB	IB
Sand	BQ	CR	CR	BQ	CR	CR
Repository SFL 2	15 200	12 500	11 300	10 200	8 800	8 100
Difference	0	-2 700	-3 900	-5 000	-6 400	-7 100

Still the presented values consider five WPC 1500 or two WPC 3750. The additional costs for two WPC 1500 and one WPC 3750, respectively, are to be considered in order to meet the peak temperature criterion set for the interior parts.

The estimate is based on a total back-fill volume of 700 000 m³ for one WPC 1500 of which 540 000 m³ is for the bentonite/sand barrier.

16.7.4 Diameter of Bentonite/sand Barrier

The 540 000 m³ of barrier would be reduced to about 430 000 m³ if the diameter of the bentonite/sand barrier was reduced by 20 m. This decrease of volume represents a cost of about MSEK 350 per cave for rock excavation and back-filling. For five caves this means about MSEK 1 750.

The result in a fully loaded WPC 1500 would be an increase of the temperature in the bentonite/sand barrier with about 20°C, to 100°C. In a WPC 1100 this decrease of the diameter seems to be acceptable without exceeding the 80°C limit, if the decrease of the peak temperature in the bentonite/sand barrier is proportional to the decrease of the peak temperature in the interior part.

16.7.5 Deeper Location of WPC

The choice of depth of the WPC for the cost estimates was made with respect to possible events occurring on the surface. It might be that a suitable site would favour a deeper location of the top part.

In such a case the cost will increase due to:

- Deeper shafts in connection with the surface, which will add extra costs for construction;
- Material transports such as rock hoisting and the bentonite and sand transportation will take a longer time.

A calculation has been conducted for an assumed 100 m lowering of the repository depth resulting in a cost increase of MSEK 150 for the total repository, SFL 2 (five WPC 1500s). About MSEK 50 are due to the increased costs for shaft excavation and MSEK 100 for material transportation.

If the repository is lowered several hundred meters further costs may add as the increased virgin temperature can cause an adjustment of the design. The rock pressure might also be a question of concern, specially in the bottom parts of the cave.

16.8 CONCLUSIONS

The initial chosen design of the WPC for the performance and safety assessment is not cost competitive, when comparing costs for such a WPC repository with those for a KBS-3 repository. This is valid even if only five WPC 1500 are required for the Swedish program of spent fuel. In course of the performance assessment it was concluded that the peak temperature in a WPC 1500 must be decreased. The most favourable way to do this was judged to be to decrease the amount of spent fuel stored in each cave. When considering such an adjustment two more caves of the same size as WPC 1500 are required, which further increases the difference in costs between the two concepts.

In order to be able to decrease the costs for the WPC concept certain feasible technical measures are available, but most of them are questionable to introduce in the light of the result from the calculations on nuclide releases. The highest costs are for the size of the WPC, the width of the bentonite/sand barrier, and the requirements on the quality of the bentonite and sand as back-fill material. In order to be able to balance the costs for a WPC repository with those of the KBS-3 repository the following measures will have to be taken:

- Increased size of WPC so that only two caves are required for the Swedish program ;
- Optimized design of inner part so that canisters are evenly distributed in the inner rock mass;
- Decreased width of bentonite/sand barrier to 2.5 m;
- Introduction of low-cost bentonite;
- Ballast fabrication from hoisted excavated rock.

These measures that are favourable from a cost point of view are contradicting the aim to improve the performance of the bentonite/sand barrier.

Although not economically optimised the WPC concept can be foreseen to introduce a higher cost level compared to the KBS-3 concept.

17 SUMMARY OF CONCLUSIONS

This chapter summarizes the conclusions on the potential of long-term safety in a WPC repository, which are drawn by the authors from the results gained in the presented calculations. At the end important topics for further R&D are listed.

17.1 GENERAL

In the nuclide release calculations conducted the order of magnitude of the dose exposures to man are indicated. The values received are considered to represent a range of values.

The most correct method would have been to present and discuss the results as a span of values for each analyzed alternative. This would, however, have required a number of calculations incorporating uncertainty analysis which is not necessary for fulfilling the general aim of the present study; to outline the potential for safety in a WPC repository and to identify the major parameters that are important to this. When also considering that doubts have been raised in the course of the study, whether the chosen WPC design in the study is satisfactory or not, it has been of even less interest to analyze the exact rates of dose exposure. Therefore, the focus in the conclusions is on one value per case, which is intended to represent the order of magnitude of the total peak rate of exposure.

17.2 COMMENTS ON RECEIVED SPAN OF DOSE EXPOSURE TO MAN

The calculations of the nuclide migration have for different scenarios resulted in peak individual doses of 10—2 000 $\mu\text{Sv}\cdot\text{a}^{-1}$ depending on the alternative. The highest value in all the alternatives is received for the combined well/lake case. The well only or lake only cases resulted in lower individual doses. Collective doses have not been estimated.

The top value of 2 000 $\mu\text{Sv}\cdot\text{a}^{-1}$ from one WPC (for fission and activation products, lower for actinides which reach their peak later) is obtained in the High Flow Through Case for a small dilution in water pumped from the well. If seven WPCs are located in a farm at one site the combined effect would, according to a simple rule of thumb in hydrology, be a dose rate about twice as high as the dose rate calculated for one WPC.

The range of individual dose rates presented lies high. The highest values are unacceptable. A reliable design should hint at a dose rate level which provides a satisfactory confidence interval below the value of 100 $\mu\text{Sv}\cdot\text{a}^{-1}$, which is used in Sweden for safeguarding the public around nuclear power stations.

17.3 COMMENTS ON IMPORTANCE OF SOME PARAMETERS

The two major parameters causing the range from 10 to 2 000 $\mu\text{Sv}\cdot\text{a}^{-1}$ are the dilution factor for released nuclides and the thermally induced flow through the repository.

If only the dilution is changed so that the amount of water to the well in which the nuclides are distributed is 250 times larger, the peak dose exposure to man from fission and activation products decreases to about 200 $\mu\text{Sv}\cdot\text{a}^{-1}$ and to 20 $\mu\text{Sv}\cdot\text{a}^{-1}$ in the later peak for the actinides.

The lowest results obtained, about 10 $\mu\text{Sv}\cdot\text{a}^{-1}$ for fission and activation products (less than 1 $\mu\text{Sv}\cdot\text{a}^{-1}$ for actinides), are for the Low Flow Through Case with a large dilution, 500 000 m^3 per year.

Thus the most important of the two parameters is the thermally induced flow.

17.3.1 Impact by Thermally Induced Flow

The driving force for the thermally induced flow is the temperature which in turn is dependent on the volume of spent fuel stored in the WPC. The temperature has in the course of this study been decreased due to the difficulties in predicting thermodynamic equilibrium data at high temperatures. It is not realistic to decrease the limit, set to 150°C, very much further as the capacity per cave then drops to too low amounts.

The magnitude of the thermally induced flow through the repository is affected by the resistance in the bentonite/sand barrier and in the inner rock mass. In the High Flow Through Case, the hydraulic conductivity in all parts of the barrier has been set to $10^{-10} \text{ m}\cdot\text{s}^{-1}$ and to $10^{-7} \text{ m}\cdot\text{s}^{-1}$ in the inner rock mass. This means that the bentonite/sand barrier alone dominates the resistance.

In order to increase the resistance over the whole structure, the hydraulic conductivity must be decreased in either the bentonite/sand barrier, the inner rock mass, or both. A decrease in the bentonite/sand barrier affects the resistance over the whole structure proportionally. A decrease in the interior part will have no effect until the hydraulic conductivity of the inner rock mass becomes so low that its resistance is comparable to the resistance of the bentonite/sand barrier. This occurs when the hydraulic conductivity of the inner rock mass is $10^{-9} \text{ m}\cdot\text{s}^{-1}$ or lower.

A sealing of fissures in the interior rock mass, which is fractured during construction of the bentonite/sand barrier, is judged to be technically too difficult and a costly process.

The bentonite/sand barrier for the case of the 10/90 bentonite/sand mixture is estimated to be made in the slot with a hydraulic conductivity of $10^{-11} \text{ m}\cdot\text{s}^{-1}$ as the lowest value. A further decrease is not very likely even for a 50/50 mixture.

In order to increase the resistance of the barrier further another engineering approach will have to be addressed. With respect to the hydrogen production during anaerobic corrosion of steel, the contradictory requirement of high conductivity in the top part must also be considered. One solution that can lead to the desired result is a design according to the "bottle" model with the opening upwards. The lower parts of the barrier are made with a low hydraulic conductivity and the uppermost part with as high a conductivity as is required due to the gas escape. The very low conductivities can be provided by pure bentonite. However, the bentonite will require special support in the bottom part of the barrier in order to take up the load from the inner rock mass. In the first design

of the WPC such support was assumed. It consisted of rock pillars. The disadvantage with this design is that the bentonite/sand barrier does not totally surround the inner rock mass.

Another alternative could be to include an impermeable membrane in the barrier, which then would serve during the time the temperature is inducing a flow of importance, i.e. for about 10 000 years. Suitable types of material have not been investigated in the course of the present study.

The conclusion is that the thermally induced flow through the repository must be prevented and decreased by a factor of about 20, in comparison to the flow in the High Flow Through Case which considers "high" conductivities in the bentonite/sand barrier and interior rock mass, in order to limit the releases to the same level as releases through diffusion. Only then it is judged possible to reach sufficiently low values of dose exposures to man. This can be achieved only by improving the hydraulic properties of the bentonite/sand barrier.

17.3.2 Impact by Dilution

The dilution factor is to a large extent a generic question related to site characteristics, but for certain scenarios the size and shape of the repository has an impact on the degree of probability of the most conservative alternative. For the WPC concept the low dilution alternative is more probable if the well has connections with one or several channels in a fracture zone, which has a high hydraulic contrast to the surrounding rock, and those fractures are in contact with the hydraulic cage. Then the major transportation path for nuclides from the repository to the surface is via the channels. Infiltration of water into those occurs almost only in the surface region. The low dilution then gives high individual doses but only to a small population, a couple of households.

On the contrary the large dilution presumes a fairly large infiltration area, on the order of some hundred thousands m^2 , but the most probable model is not known. A larger dilution volume than 500 000 m^3 is not considered plausible for one WPC.

The characteristics with an influence on the dilution factor are easily identified in geophysical site investigations and the unfavourable locations are thus possible to avoid. The critical question is, however, how much will this limit the flexibility of locating a WPC repository. This can not be quantified based on the preliminary data from different sites presented so far.

17.3.3 Time of Fuel Dissolution

A shorter dissolution time, 20 000 years instead of 1 200 000 years, which corresponds to a 5 times higher dissolution rate, results in at the most a 2 times higher total dose exposure. Short-lived non-sorbing nuclides, e.g. C-14, are most affected. This result implies that the dissolution time has a minor impact on the total dose exposure.

17.3.4 Sorption in Corroded Canister Walls

Although the iron corrosion products have a good sorption capacity, its total capacity is on the same order of magnitude as the capacity in the back-filled finely ground rock material, which is small compared to the capacity of the ben-

tonite/sand barrier. Thus the impact of sorption in the corroded canister walls is small.

17.3.5 Sorption in Rock Mass Inside Bentonite/sand Barrier

The potential total sorption capacity in the inner rock mass is large. For dose dominating fission products this fact is of no importance, since they have a very low sorption coefficient. For actinides this fact can have an impact of importance. The total capacity is, however, not possible to utilize, since the time to reach equilibrium is judged to be several orders of magnitude longer than the half-times of the nuclides.

17.3.6 Bentonite/sand Barrier Thickness

When considering nuclide migration by diffusion only, a halved thickness from 5 m to 2.5 m results in an increase by at most a factor of 5 in the dose exposure rate.

When flow is the dominating transport mechanism and the bentonite/sand barrier is the dominating resistance against flow, a change in the barrier thickness with a factor of 2 affects the flow through and thus the nuclide release rate also by a factor of 2.

This means that the impact of the barrier thickness is of moderate importance. The major concern regarding the barrier is to construct it with a satisfactory total resistance against flow. In order to fulfill this with the present design the need for a thicker barrier is more probable than the possibility of allowing a decrease.

17.3.7 Migration Distance in Geosphere

The result of the channeling model is that the transportation velocity is relatively high and that the total surface area available for sorption is small. The retardation in the geosphere is consequently small. The transportation distance from the repository to the biosphere must be in the range of 1 000 m or longer before any noticeable effect is seen, and that is for sorbing nuclides. The dose dominating fission and activation products are not affected.

Thus the transportation distance for nuclides in the geosphere is of negligible importance if the channeling concept is adopted.

17.4 HYDRAULIC CAGE

The presence of the cage is not totally positive for all types of bedrock characteristics. The cage is sensitive to existing "rapid" water transporting channels in the bedrock, since those channels, if intersected, will act as the major transportation paths for the nuclides.

No difference has been seen in the thermally induced flow out through the top of the bentonite/sand barrier between the cases with and without the hydraulic cage. The cage seems to have negligible effect on the thermally induced flow inside. Buoyancy cells tend to develop in the drains of the cage with an effective mixing of the water in the cage as a result.

The positive effects of the cage are, however, dominating in the later phase, but it remains to be shown that the cage can maintain its function also in the long-term perspective.

17.5 ECONOMY

The costs for a WPC repository is significantly higher than the costs for a KBS-3 repository with respect to the Swedish situation. The major parameter is the cost for excavating and buffer mass filling of the bentonite/sand barriers.

The potential for cost saving simplifications is high, but it is not considered possible to reach a level with the present design where the WPC is less expensive than KBS-3.

17.6 POTENTIAL OF SAFETY

In the studied design the dominating barrier against thermally induced flow is the bentonite/sand barrier. Later, when the temperature has decreased, this barrier still is vital, since the natural flow may dominate the radionuclide release, if the hydraulic conductivity of the barrier is not satisfactorily low or the hydraulic cage is not satisfactorily effective. For normal performance of the presented design, however, diffusion through the bentonite/sand barrier dominates the radionuclide release after the period with thermally induced flow.

It is judged feasible to design and construct a WPC repository in Sweden which fulfills the high demands on the short-term as well as long-term safety. The conclusion is, however, that adjustments are required in the present design if low release rates are to be achieved. The prime concern in this respect is the hydraulic conductivity of the bentonite/sand barrier, which most likely must be improved beyond the values possible for low-graded bentonite buffer masses.

A radical adjustment would be to change the short-lived steel canister for a long-lived design, e g, the copper canister assumed in the Swedish program. Thereby the start of the dissolution of the fuel is delayed to the time when fission and activation products have decayed to insignificant levels. Also the thermal power decreases then to a negligible low level.

17.7 TOPICS REQUIRING FURTHER R&D

Several very important questions remain to be attended to in the case of further development of the WPC concept.

1. Engineering in order to improve the hydraulic conductivity of the bentonite/sand barrier, the interior rock mass, and the rock mass outside the bentonite/sand barrier.
2. Life-time of steel canisters.
3. Thermodynamic equilibrium data at elevated temperatures.
4. Dissolution mechanism and dissolution rate of the fuel.
5. Sorption coefficients at elevated temperatures.

6. Migration of dissolved nuclides inside the canister, through the canister walls, and in the vicinity of the canisters surface.
7. More detailed analysis of thermo-induced flow through and around a repository.
8. Migration of dissolved nuclides in the geosphere in terms of transport paths and available sorption capacity.
9. Rates of hydrogen production during anaerobic corrosion of steel.
10. Rates of evacuating hydrogen gas in the rock mass surrounding the repository.
11. Performance of the hydraulic cage in the long run with respect to the ground water flow pattern in the bedrock as well as with respect to clogging due to precipitation of minerals.
12. Site specific analysis concerning the existences of gently dipping fracture zones with high hydraulic contrast to the surrounding bedrock.

If copper canisters are assumed some of the topics mentioned above would be of less interest to study while others, like corrosion of copper, would be added to the list. The specific, new question for a WPC with copper canisters would be to analyse the importance of the temperature for the corrosion of copper and estimate the life-time of copper canisters in the environment prevailing in a WPC.

REFERENCES

Andersson K, Torstenfelt B, Rydberg J, 1979:

“Leakage from an Underground Rock Repository”, Chalmers University of Technology, Gothenburg.
KBS Technical Report 79-26, Stockholm, Sweden.

Arve S, Moreno L, Neretnieks I, 1988:

“Transport of Escaping Activation and Fission Products from the WP-Cave Repository to the Biosphere”, Department of Chemical Engineering, Royal Institute of Technology.
SKB AR 88-15, Stockholm, Sweden.

Baes C F, Mesmer R E, 1976:

“The Hydrolysis of Cations”, John Wiley and Sons, New York, USA.

Christiansson R, Bolvede P, Rosengren L, 1987:

“WP-Cave i blockigt berg”, VIAK AB.
SKB AR 87-18, Falun, Sweden.

Claesson T, 1983:

“Water-Rock Interaction at Elevated Temperatures. Chemical Changes in Water Composition”, Department of Geology, Chalmers University of Technology and University of Gothenburg, Publ. A44, Gothenburg, Sweden.

Christensen H, Bjergbakke E, 1987:

“Radiolysis of Ground Water from Spent Fuel Stored According to the WP-Cave Concept”, Studsvik Energiteknik AB.
SKB AR 87-21, Stockholm, Sweden.

Forsyth R S, Werme L O, Bruno J, 1986:

“The Corrosion of Spent UO₂ Fuel in Synthetic Groundwater”, Studsvik Energiteknik AB, SKB and Department of Inorganic Chemistry, Royal Institute of Technology.
J. Nucl. Mater., 138 (1986) 1-15.

Grenthe I, 1989:

“Personal communication.” Department of Inorganic Chemistry, Royal Institute of Technology, Stockholm, Sweden.

Hopkirk R J, 1988:

“SKB WP-Cave Project. Thermally Induced Convective Motion in Ground Water in the near Field of the WP-Cave after Filling and Closure”, Polydynamics Limited, Zürich, Switzerland.
SKB Technical Report 89-08, Stockholm, Sweden.

Karlsson L-G, Höglund L-O, Pers K, 1986:

“Nuclide Release from the Near-Field of a L/ILW Repository”, Kemakta Consultants Co, Stockholm.
NAGRA Technical Report 85-33, Baden, Switzerland.

KBS-3 1983:

“Final Storage of Spent Nuclear Fuel”.
Report by the Swedish Nuclear Fuel and Waste Management Co., Stockholm, Sweden.

Lindblom U, 1988:

“Escape Conditions for Hydrogen in the Host Rock Surrounding a WP-Cave”, Geological Engineering consultants GECON AB.
SKB AR 89-10, Gothenburg, Sweden.

Lindgren M, Skagius K, 1989:

“SKB WP-Cave Project. Radionuclide Release from the Near-Field in a WP-Cave Repository”, Kemakta Consultants Co.
SKB Technical Report 89-04.

Marsh G P, 1985:

“Assessment of the Corrosion Behavior of the Canister and Structural Material in the WP-Cave Repository Concept. Part 1 - During Operational Period”, AERE Harwell Report AERE-G3522, Harwell, Great Britain.

Marsh G P, 1985:

“Assessment of the Corrosion Behavior of the Canister and Structural Material in the WP-Cave Repository Concept. Part 2 - Canister Corrosion after Closure”, AERE Harwell Report AERE-G3626, Harwell, Great Britain.

Marsh G P, Bland I D, Taylor K J, Sharland S M, Tasker P W, 1986:

“An Assessment of Carbon Steel Overpacks for Radioactive Waste Disposal”, Commission of European Communities, Nuclear Science and Technology, Report EUR 10437 EN.

Marsh G P, Taylor K J, Sharland S M, Tasker P W, 1987:

“An Approach for Evaluating the General and Localized Corrosion of Carbon Steel Containers for Nuclear Waste Disposal”, in: Scientific Basis for Nuclear Waste Management -X, editors: Bates J.K. and Seefeldt W.B., Materials Research Society Symposia Proceedings, Vol. 84, p 227.

Moreno L, Arve S, Neretnieks I, 1988:

“Transport of Escaping Radionuclides from the WP-Cave Repository to the Biosphere”, Department of Chemical Engineering, Royal Institute of Technology.
SKB Technical Report 89-05, Stockholm, Sweden.

Neretnieks I, Andersson K, 1978:

“Utläckning av Ni-59 från ett bergförvar”, Department of Chemical Engineering, Royal Institute of Technology, Stockholm. KBS Technical Report 101, Stockholm, Sweden.

Nordlinder S, Bergström U, 1989:

“SKB WP-Cave Project. Individual Radiation Doses from Nuclides Contained in a WP-Cave Repository for Spent Fuel”, Studsvik Nuclear, Studsvik.
SKB Technical Report 89-06, Stockholm, Sweden.

Skagius K, Bengtsson A, Lindgren M, 1988:

“Release of Fission and Activation Products from the Bentonite-Sand Barrier in a Wp-Cave Repository”, Kemakta Konsult AB.
SKB AR 88-14, Stockholm, Sweden.

SKB, 1987:

“Kostnader för kärnkraftens radioaktiva slutprodukter. Slutförvar enligt WP-Cave”, ABV, ASEA-Atom, Boliden WP-Contech AB, SKB, VBB.
SKB AR 87-03, Stockholm, Sweden.

SKB, 1989:

“SKB WP-Cave Project. Some Notes on Technical Issues”.
SKB TR 89-07, Stockholm, Sweden.

SKB PLAN 86, 1986:

“Costs for Management of the Radioactive Waste from Nuclear Power Production”.
SKB Technical Report 86-12, Stockholm, Sweden.

SKN Report 16, 1985:

“NAK WP-Cave Project. Report on the Research and Development Stage May 1984 to October 1985”, Boliden WP-Contech AB, National Board for Spent Nuclear Fuel Report 16, Stockholm, Sweden.

White L, 1984:

“Boliden cut-and-fill: Not just a means of mining weak ground”, Engineering and Mining Journal, August 1984.

Wiborgh M, Lindgren M, 1987:

“Database for the Radionuclide Transport Calculations for SFR”, Kemakta Consultants Co, Stockholm.
SKB Progress Report SFR 87-09, Stockholm, Sweden.

Wilson C N, Oversby V M, 1985:

Waste Management '85, Ed: Post R.G., Proc. of the Symposium on Waste Management at Tucson, Arizona, 1985, Vol 1, p 497.

Åkesson B Å, Hök J H, 1977:

“Rock Cavern with Clay Barrier for Disposal of nuclear Wastes”, Chalmers University of Technology, Gothenburg and WP-System AB, Stockholm. Storage in Excavated Rock Caverns (Rockstore 77), proceedings of the First International Symposium, edited by Magnus Bergman, Volume 3, pp 811-820, Stockholm, Sweden.

RESULT OF SKN STUDY

The text below presents in brief the aim of the SKN study on the WPC and summarizes the major outcomes of the analysis and conclusions drawn.

STUDY PROGRAM

The aim of the study, which was conducted during May 1984 to October 1985, was to address issues specific to the WPC concept and with importance to the long-term safety and integrity of the repository as well as to the possibility of constructing a WPC repository. A priority of this kind was necessary in order to fit the program into the given frames of time and funds. The major topics analyzed are:

- Design of steel canisters;
- Corrosion behaviour of carbon steel;
- Mining and full-face boring techniques;
- Temperature distribution and thermal stresses induced;
- Air-ventilation of storage;
- Properties of bentonite/sand mixtures;
- Function of hydraulic cage;
- Ground water filling time after closure.

In addition an initial safety analysis was made, but based on available models, e.g. those developed for the KBS-3 design.

STUDY RESULTS

Altogether the results obtained were positive. No major obstacle was found that invalidated the basic principles of the concept.

The initial and very preliminary safety analysis resulted in dose levels judged to be reasonable. However, the interpretation of the values received in the calculations was coupled with a high degree of uncertainty as some barrier functions could not be considered with the appropriate accuracy due to lack of data or time for correct modelling.

Further results of the laboratory tests and computer analyses were:

- The WPC can be constructed with established mining technology;
- Canisters can be constructed in carbon steel. The corrosion and mechanical design studies indicated that a wall thickness of 100—150 mm is required. The anaerobic corrosion of the canisters, as well as of steel liners in shafts, might cause a fairly high rate of production of hydrogen gas;
- The cooling by air during the 100-year period can be maintained by self-circulation of the air. No fans are required once the circulation has been initiated;
- The experiments with different bentonite/sand mixtures indicate that a mixture of 10% bentonite has satisfactory swelling and mechanical properties for being used in the bottom cone. The hydraulic conductivity of such a mixture, however, was estimated to be 10^{-11} m s⁻¹ as the lowest value. This was a drawback compared to assumptions earlier made in the project where the ben-

tonite/sand slot was estimated to be made with a hydraulic conductivity of 10^{-13} to 10^{-14} ms^{-1} ;

- The higher conductivity means that the inner part of the cave is water-filled very quickly, in less than 100 years;
- The estimated conductivity of 10^{-10} — 10^{-11} ms^{-1} was, however, judged to be satisfactory for preventing natural flow through the repository and allowing diffusion through the bentonite/sand barrier to be the major mechanism for nuclide releases to the geosphere;
- With increased bentonite content the mixture tends to have a lower hydraulic conductivity. A 50% mixture was considered good enough for the top cone. Laboratory tests also showed that such a bentonite-rich mixture should have a sufficiently high gas conductivity for the gas to escape through;
- The function of the hydraulic cage was found to be more effective than previously assumed. The calculations showed a greater potential for a high ground water diversion efficiency by a hydraulic cage than by a bentonite/sand barrier.

Based on the positive results the Project Board of the SKN study strongly recommended that the research and development work on the WPC continued. The prime concern in the next stage was considered to be a more detailed and accurate safety analysis.

STUDY ORGANIZATION

This appendix presents the organization of the project work. In connection with the listing of different technical studies only the most involved researchers and scientists, however, are mentioned.

PROJECT ORGANIZATION

The actual project work has been administrated within the SKB organization.

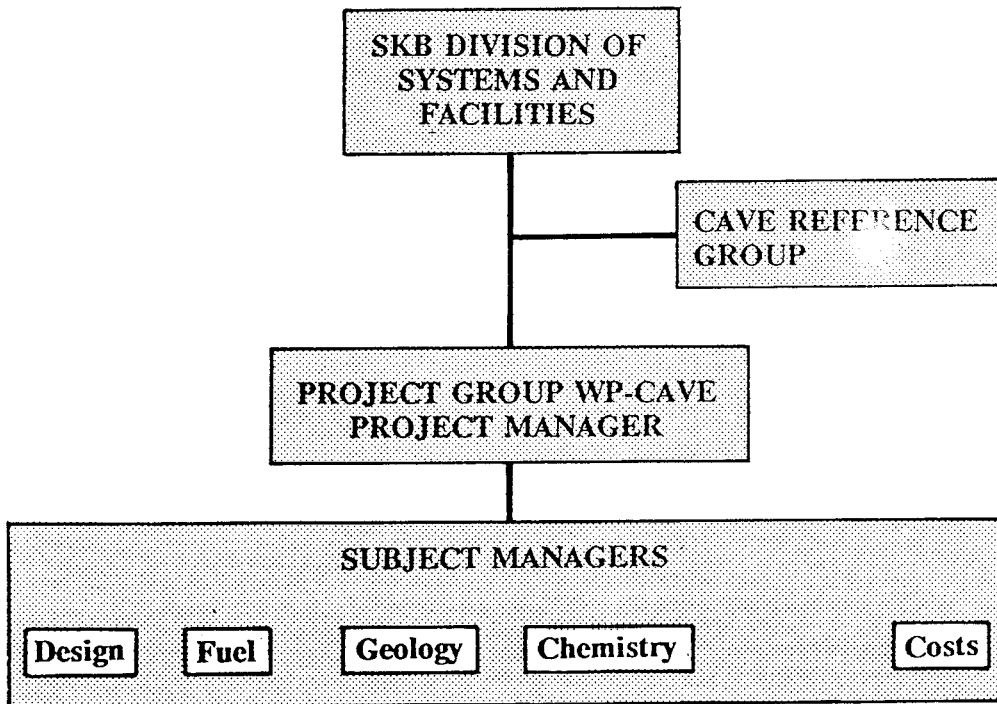

The conducted performance and safety assessments have been guided by discussions and recommendations in the Reference Group, which has had the following members:

Cave Reference Group

Members

Mr Hans Forsström,	SKB	Chairman
Mr Per-Eric Ahlström,	SKB	
Dr Sten G A Bergman,	Independent Consultant	
Prof Ingmar Grenthe,	Royal Institute of Technology	
Prof Gunnar Gustafson,	Chalmers University of Technology	
Mr Nils Rydell,	National Board for Spent Nuclear Fuel	
Prof Bengt Åkesson,	Chalmers University of Technology	

Co-opted Members

Prof Ivars Neretnieks,	Royal Institute of Technology	
Mr Tönis Papp,	SKB	
Dr Kristina Skagius,	Kemakta Konsult AB	
Mr Christer Svemar,	SKB	

The major part of the safety assessment comprised the modelling and calculation of nuclide migration. A temporary project group was coordinating the work concerning the near field, far field, and biosphere.

Cave Kemi Group

Members

Mr Christer Svemar,	SKB	Chairman
Dr Kristina Skagius,	Kemakta Konsult AB	(Near field)
Mrs Sue Arve,	Royal Institute of Technology (to June 1988)	(Far field)
Mr Luis Moreno,	Royal Institute of Technology	"
Mr Sture Nordlinder,	Studsvik Energiteknik AB	(Biosphere)
Dr Fred Karlsson,	SKB	
Mr Lars Werme,	SKB	

DETAILED STUDIES

The bases of input data for models, calculations, and evaluation of the performance and safety analysis have been provided by a number of studies with major contributors as follows:

Design of WPC 1500 and WPC 3750

Boliden WP-Contech AB.

Temperature Distribution

Stefan Björklund and Lennart Josefson, Division of Solid Mechanics, Chalmers University of Technology.

Rock Mechanics Aspects

Ulf Håkansson, Lars Hässler and Håkan Stille, Department of Soil and Rock Mechanics, Royal Institute of Technology.

Thermally Induced Ground Water Flow

Robert Hopkirk, Polydynamics Ltd, Switzerland.

Steel Corrosion

Lars Werme, SKB

Hydrogen Gas Migration

Luis Moreno and Ivars Neretnieks, Department of Chemical Engineering, Royal Institute of Technology and Ulf Lindblom, Gecon AB.

Radiolysis of Ground Water

Erling Bjergbakke, Risø National Laboratory, Denmark and Hilbert Christensen, Studsvik Energiteknik AB.

Fuel Dissolution

Lars Werme, SKB.

Chemical Environment and Nuclide Migration in Near Field

Akke Bengtsson, Lars-Gunnar Karlsson, Maria Lindgren and Kristina Skagius, Kemakta Konsult AB.

Nuclide Migration in Far Field

Sue Arve, Luis Moreno and Ivars Neretnieks, Department of Chemical Engineering, Royal Institute of Technology.

Dilution of Nuclides Reaching a Well

Ivars Neretnieks, Department of Chemical Engineering, Royal Institute of Technology.

Dispersion in Biosphere

Ulla Bergström and Sture Nordlinder, Studsvik Energiteknik AB.

Cost Analysis

In addition a comprehensive cost analysis was carried out in a very early stage of the SKB-WP-CAVE project. The calculations were made by the same group that runs the annual PLAN reports on costs for the whole Swedish back-end system. The group has representatives from the following companies:

- ASEA-Atom (now ABB-Atom, Asea Brown Boveri)
- ABV, Armerade Betong och Vägförbättringar (now NCC, Nordic Construction Company)
- VBB, Väg-och vattenbyggnadsbyrån

and in the case of the WPC analysis also Boliden WP-Contech AB.

INTEGRATED PERFORMANCE GROUP (SAMFUNKTIONSGRUPPEN)

The task of supervising the quality of the performance and safety analysis and of comparing the WPC concept with the established Reference Alternative KBS-3 has been managed by the special group within SKB, called Samfunktionsgruppen (Integrated Performance Group), abbreviated SFG. This group started its work on WPC in the beginning of 1987 with the following members:

Samfunktionsgruppen, SFG

Members

Mr Tönis Papp,	SKB	Chairman
Dr Fred Karlsson,	SKB	
Mr Nils Kjellbert,	SKB	Secretary
Prof Ivars Neretnieks,	Royal Institute of Technology	
Dr Lars Werme,	SKB	

This group has besides its main tasks to ensure a satisfactory detailed level in analyses of the WPC concept and to compare WPC and KBS-3 with respect to performance and safety, contributed to the project work with elucidatory discussions in technical issues and beneficial recommendations in study priorities.

Additional Members

in the course of the study have been:

Dr Kristina Skagius	Kemakta Konsult AB
Mr Christer Svemar	SKB, Project Manager of WPC study

ALTERNATIVE WPC DESIGNS

In this appendix three alternative designs are presented. One is the same size as WPC 1100 but has a capacity of 1500 tonnes of U. The second is the large size that has a capacity of between one half and one third of the Swedish program. The third is the layout with no bottom in the bentonite/sand barrier.

WPC 1500

The measures of the WPC 1500 design are the same as of WPC 1100, see Figure 2-1.

In each canister channel there is space available for storing three canisters. The measures further assume a number of 16 canister levels giving positions for 576 canisters in total, an amount which corresponds to 1/5 of the Swedish program of spent fuel.

The limitation on the capacity is the temperature. If the canister channels are not to be filled with finely ground rock, the limit of 150°C may be fulfilled with a tonnage of more than 1100 tonnes of U.

WPC 3750

A larger design considered, basically because of the lower investment, is a size of WPC that could store at maximum half of the Swedish program, assumed to be 3 750 tonnes of U at the time of the study. The dimensions of this size is shown in Figure App3-1.

NO BOTTOM IN BENTONITE/SAND BARRIER

In the SKN study an alternative design of the bentonite/sand barrier was considered; without the bottom cone, see Figure App3-2. The advantage would be a more defined and homogeneous rock mass inside the barrier after excavation. Uncertainties, however, to analyze are whether the bottom part of the rock would be tight or if transport paths would open for water to enter into the inner repository. The rock mechanics analyses in the SKN study /SKN Report 16, Chapter 8, 1985/ indicate that weak zones may develop in the rock mass below the bentonite/sand barrier.

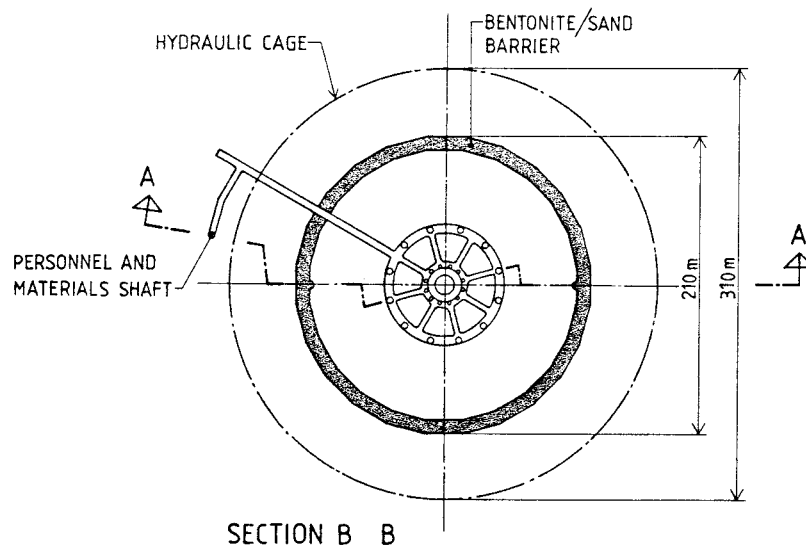
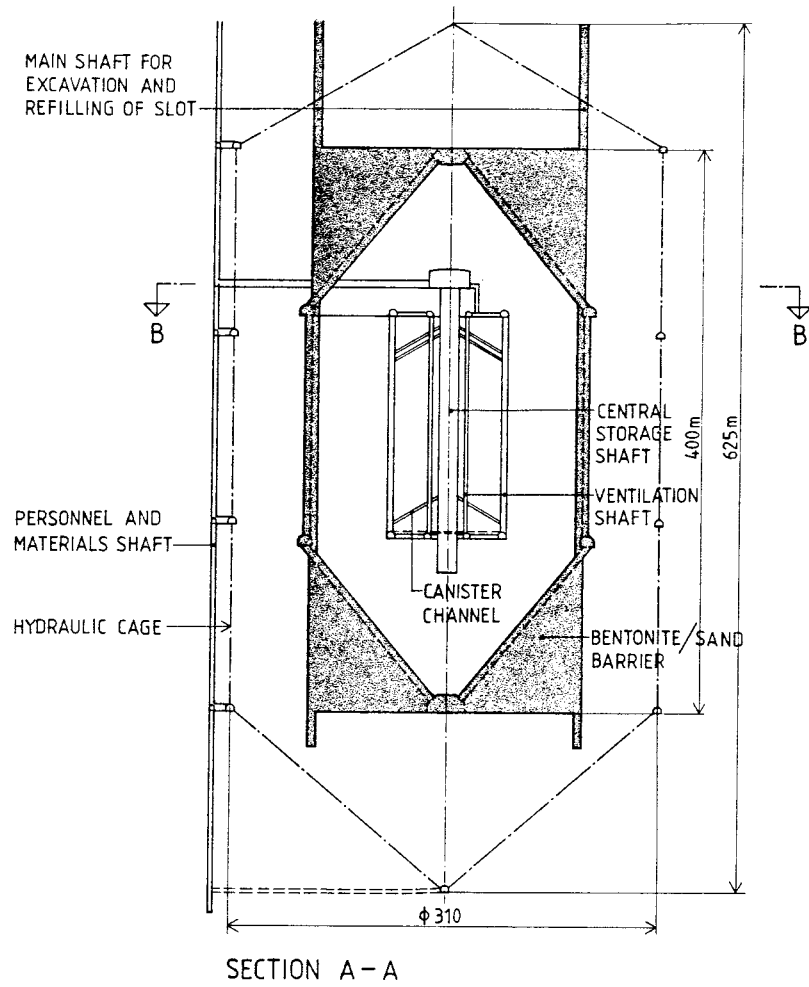

Figure App3-1. WPC 3750.

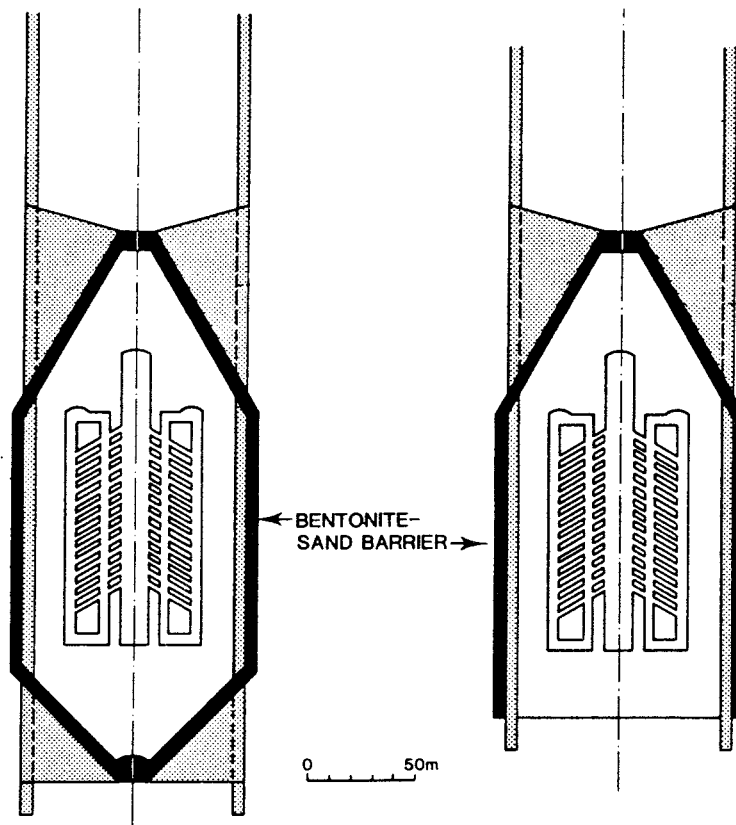

Figure App3-2. Two alternative designs of the bentonite/sand barrier. Left hand side alternative **with** bottom cone. Right hand side alternative **without** bottom cone.

BASIC DATA FOR WPC STUDY (WPC 1100)

1. Repository Dimensions

Diameter hydraulic cage =	230 m
Diameter, bentonite/sand barrier =	130 m
Height, " " " =	300 m
Diameter, canister channels =	1.7 m
Diameter, outer ventilation shafts =	3 m
inner " " =	2 m
Distance outer ventilation shafts to bentonite/sand barrier =	30 m

2. Canister Data

length =	5 m
diameter, inner =	1.08 m
outer =	1.30 m

3. Fuel Data

Type PWR, 38 GWd · (tU) ⁻¹	
Total amount in repository =	1100 tonnes
Inventory at canister breakthrough	see Table 15-1
Nuclide solubilities	see Table 15-2

4. Back-filled Finely Ground Rock

Total back-filled volume =	75 000 m ³
Volume utilized for sorption =	1 800 m ³ (0.2 m x 9 000 m ²)
Porosity =	30%
Density (solid) =	2 700 kg · m ⁻³
Density (bulk) =	1 890 kg · m ⁻³
Nuclide pore diffusivity =	2 · 10 ⁻⁹ m ² · s ⁻¹
Sorption capacity	see Table 15-3

5. Inner Rock Mass

Hydraulic conductivity =	10 ⁻⁹ m · s ⁻¹ (Low Flow Through Case)
=	10 ⁻⁷ m · s ⁻¹ (High " " ")
Porosity =	0.1%
Density =	2 700 kg · m ⁻³
Thermal conductivity =	3.35 W · (m ⁻¹ K ⁻¹)
Specific heat =	2.16 MJ · (m ⁻³ K ⁻¹)

6. Bentonite/sand Barrier

Total volume =	485 000 m ³ (5 m x 97 000 m ²)
Porosity =	25%
Density (solid) =	2 666 kg·m ⁻³
Density (bulk) =	2 000 kg·m ⁻³
Nuclide pore diffusivity =	4·10 ⁻¹⁰ m ² ·s ⁻¹
Sorption capacity	see Table 15-3
Hydraulic conductivity =	10 ⁻¹¹ (Low Flow Through Case)
=	10 ⁻¹⁰ (High Flow Through Case)
Thermal conductivity =	1.4 W·(m ⁻¹ K ⁻¹)
Specific heat =	1.6 MJ·(m ⁻³ K ⁻¹)

7. Geosphere

Ground water flow rate =	0.3·10 ⁻³ m ³ ·m ⁻² ·a ⁻¹
Flow porosity =	0.1%
Channel, length =	100 m
width =	1 m
aperture =	0.25 mm
Flow distribution between channels	see Table 15-5
Effective diffus. in rock matrix =	5·10 ⁻¹⁴ m ² ·s ⁻¹
Sorption capacity of rock matrix	see Table 15-3
Hydraulic conductivity =	10 ⁻⁹ m·s ⁻¹
Thermal conductivity =	3.35 W·(m ⁻¹ K ⁻¹)
Specific heat =	2.16 MJ·(m ⁻³ K ⁻¹)

8. Biosphere

Lake volume =	3.2·10 ⁶ m ³
Dilution in well =	500 000 m ³ ·a ⁻¹
	2 000 m ³ ·a ⁻¹

Input data to the BIOPATH model are exemplified in Tables 15-8 to 15-13.
For more detailed information about input data see /Nordlinder and Bergström,
1989/.

List of SKB reports

Annual Reports

1977-78

TR 121

KBS Technical Reports 1 – 120.

Summaries. Stockholm, May 1979.

1979

TR 79-28

The KBS Annual Report 1979.

KBS Technical Reports 79-01 – 79-27.
Summaries. Stockholm, March 1980.

1980

TR 80-26

The KBS Annual Report 1980.

KBS Technical Reports 80-01 – 80-25.
Summaries. Stockholm, March 1981.

1981

TR 81-17

The KBS Annual Report 1981.

KBS Technical Reports 81-01 – 81-16.
Summaries. Stockholm, April 1982.

1982

TR 82-28

The KBS Annual Report 1982.

KBS Technical Reports 82-01 – 82-27.
Summaries. Stockholm, July 1983.

1983

TR 83-77

The KBS Annual Report 1983.

KBS Technical Reports 83-01 – 83-76
Summaries. Stockholm, June 1984.

1984

TR 85-01

Annual Research and Development Report 1984

Including Summaries of Technical Reports Issued during 1984. (Technical Reports 84-01-84-19)
Stockholm June 1985.

1985

TR 85-20

Annual Research and Development Report 1985

Including Summaries of Technical Reports Issued during 1985. (Technical Reports 85-01-85-19)
Stockholm May 1986.

1986

TR 86-31

SKB Annual Report 1986

Including Summaries of Technical Reports Issued during 1986
Stockholm, May 1987

1987

TR 87-33

SKB Annual Report 1987

Including Summaries of Technical Reports Issued during 1987

Stockholm, May 1988

1988

TR 88-32

SKB Annual Report 1988

Including Summaries of Technical Reports Issued during 1988

Stockholm, May 1989

Technical Reports

1989

TR 89-01

Near-distance seismological monitoring of the Lansjärv neotectonic fault region Part II: 1988

Rutger Wahlström, Sven-Olof Linder,
Conny Holmqvist, Hans-Edy Mårtensson
Seismological Department, Uppsala University,
Uppsala
January 1989

TR 89-02

Description of background data in SKB database GEOTAB

Ebbe Eriksson, Stefan Sehlstedt
SGAB, Luleå
February 1989

TR 89-03

Characterization of the morphology, basement rock and tectonics in Sweden

Kennert Röshoff
August 1988

TR 89-04

SKB WP-Cave Project Radionuclide release from the near-field in a WP-Cave repository

Maria Lindgren, Kristina Skagius
Kemakta Consultants Co, Stockholm
April 1989

TR 89-05

SKB WP-Cave Project Transport of escaping radionuclides from the WP-Cave repository to the biosphere

Luis Moreno, Sue Arve, Ivars Neretnieks
Royal Institute of Technology, Stockholm
April 1989

TR 89-06

**SKB WP-Cave Project
Individual radiation doses from nuclides
contained in a WP-Cave repository for
spent fuel**

Sture Nordlinder, Ulla Bergström
Studsvik Nuclear, Studsvik
April 1989

TR 89-07

**SKB WP-Cave Project
Some Notes on Technical Issues**

- Part 1: Temperature distribution in WP-Cave: when shafts are filled with sand/water mixtures
Stefan Björklund, Lennart Josefson
Division of Solid Mechanics, Chalmers University of Technology, Gothenburg, Sweden
- Part 2: Gas and water transport from WP-Cave repository
Luis Moreno, Ivars Neretnieks
Department of Chemical Engineering, Royal Institute of Technology, Stockholm, Sweden
- Part 3: Transport of escaping nuclides from the WP-Cave repository to the biosphere.
Influence of the hydraulic cage
Luis Moreno, Ivars Neretnieks
Department of Chemical Engineering, Royal Institute of Technology, Stockholm, Sweden

August 1989

TR 89-08

**SKB WP-Cave Project
Thermally induced convective motion in
groundwater in the near field of the
WP-Cave after filling and closure**

Polydynamics Limited, Zürich
April 1989

TR 89-09

**An evaluation of tracer tests performed
at Studsvik**

Luis Moreno¹, Ivars Neretnieks¹, Ove Landström²
¹ The Royal Institute of Technology, Department of
Chemical Engineering, Stockholm
² Studsvik Nuclear, Nyköping
March 1989

TR 89-10

**Copper produced from powder by HIP to
encapsulate nuclear fuel elements**

Lars B Ekbohm, Sven Bogegård
Swedish National Defence Research Establishment
Materials department, Stockholm
February 1989

TR 89-11

**Prediction of hydraulic conductivity and
conductive fracture frequency by multi-
variate analysis of data from the Klipperås
study site**

Jan-Erik Andersson¹, Lennart Lindqvist²
¹ Swedish Geological Co, Uppsala
² EMX-system AB, Luleå
February 1988

TR 89-12

**Hydraulic interference tests and tracer tests
within the Brändan area, Finnsjön study site
The Fracture Zone Project – Phase 3**

Jan-Erik Andersson, Lennart Ekman, Erik Gustafsson,
Rune Nordqvist, Sven Tirén
Swedish Geological Co, Division of Engineering
Geology
June 1988

TR 89-13

**Spent fuel
Dissolution and oxidation
An evaluation of literature data**

Bernd Grambow
Hahn-Meitner-Institut, Berlin
March 1989

TR 89-14

**The SKB spent fuel corrosion program
Status report 1988**

Lars O Werme¹, Roy S Forsyth²
¹ SKB, Stockholm
² Studsvik AB, Nyköping
May 1989

TR 89-15

**Comparison between radar data and
geophysical, geological and hydrological
borehole parameters by multivariate
analysis of data**

Serje Carlsten, Lennart Lindqvist, Olle Olsson
Swedish Geological Company, Uppsala
March 1989

TR 89-16

**Swedish Hard Rock Laboratory –
Evaluation of 1988 year pre-investigations
and description of the target area, the
island of Äspö**

Gunnar Gustafsson, Roy Stanfors, Peter Wikberg
June 1989

TR 89-17

**Field instrumentation for hydrofracturing stress measurements
Documentation of the 1000 m hydrofracturing unit at Luleå University of Technology**

Bjarni Bjarnason, Arne Torikka
August 1989

TR 89-18

Radar investigations at the Saltsjötunnel – predictions and validation

Olle Olsson¹ and Kai Palmqvist²

¹ Abem AB, Uppsala, Sweden

² Bergab, Göteborg

June 1989

TR 89-19

Characterization of fracture zone 2, Finnsjön study-site

Editors: K. Ahlbom, J.A.T. Smellie, Swedish Geological Co, Uppsala

Part 1: Overview of the fracture zone project at Finnsjön, Sweden

K. Ahlbom and J.A.T. Smellie. Swedish Geological Company, Uppsala, Sweden.

Part 2: Geological setting and deformation history of a low angle fracture zone at Finnsjön, Sweden

Sven A. Tirén. Swedish Geological Company, Uppsala, Sweden.

Part 3: Hydraulic testing and modelling of a low-angle fracture zone at Finnsjön, Sweden

J-E. Andersson¹, L. Ekman¹, R. Nordqvist¹ and A. Winberg²

¹ Swedish Geological Company, Uppsala, Sweden

² Swedish Geological Company, Göteborg, Sweden

Part 4: Groundwater flow conditions in a low angle fracture zone at Finnsjön, Sweden

E. Gustafsson and P. Andersson. Swedish Geological Company, Uppsala, Sweden

Part 5: Hydrochemical investigations at Finnsjön, Sweden

J.A.T. Smellie¹ and P. Wikberg²

¹ Swedish Geological Company, Uppsala, Sweden

² Swedish Nuclear Fuel and Waste Management Company, Stockholm, Sweden

Part 6: Effects of gas-lift pumping on hydraulic borehole conditions at Finnsjön, Sweden

J-E. Andersson, P. Andersson and E. Gustafsson. Swedish Geological Company, Uppsala, Sweden

August 1989

TR 89-20

WP-Cave - Assessment of feasibility, safety and development potential

Swedish Nuclear Fuel and Waste Management Company, Stockholm, Sweden
September 1989

TR 89-21

Rock quality designation of the hydraulic properties in the near field of a final repository for spent nuclear fuel

Hans Carlsson¹, Leif Carlsson¹, Roland Pusch²

¹ Swedish Geological Co, SGAB, Gothenburg, Sweden

² Clay Technology AB, Lund, Sweden

June 1989

TR 89-22

Diffusion of Am, Pu, U, Np, Cs, I and Tc in compacted sand-bentonite mixture

Department of Nuclear Chemistry, Chalmers University of Technology, Gothenburg, Sweden

August 1989

TR 89-23

Deep ground water microbiology in Swedish granitic rock and it's relevance for radionuclide migration from a Swedish high level nuclear waste repository

Karsten Pedersen

University of Göteborg, Department of Marine microbiology, Gothenburg, Sweden

March 1989

TR 89-24

Some notes on diffusion of radionuclides through compacted clays

Trygve E Eriksen

Royal Institute of Technology, Department of Nuclear Chemistry, Stockholm, Sweden

May 1989

TR 89-25

**Radionuclide sorption on crushed and intact granitic rock
Volume and surface effects**

Trygve E Eriksen, Birgitta Locklund

Royal Institute of Technology, Department of Nuclear Chemistry, Stockholm, Sweden

May 1989